

Winter 2010

Ordinary Creativity in Patent Law: The Artist within the Scientist

Amy L. Landers

Follow this and additional works at: <https://scholarship.law.missouri.edu/mlr>



Part of the [Law Commons](#)

Recommended Citation

Amy L. Landers, *Ordinary Creativity in Patent Law: The Artist within the Scientist*, 75 MO. L. REV. (2010)
Available at: <https://scholarship.law.missouri.edu/mlr/vol75/iss1/2>

This Article is brought to you for free and open access by the Law Journals at University of Missouri School of Law Scholarship Repository. It has been accepted for inclusion in Missouri Law Review by an authorized editor of University of Missouri School of Law Scholarship Repository. For more information, please contact bassettcw@missouri.edu.

MISSOURI LAW REVIEW

VOLUME 75

WINTER 2010

NUMBER 1

ARTICLES

Ordinary Creativity in Patent Law: The Artist Within the Scientist

*Amy L. Landers**

Patent law is intended to promote the creativity of scientists and engineers. The system recognizes that the work of the individual is the engine that ultimately increases the state of scientific knowledge. As economist Paul Romer recognized, "Technological advance comes from things that people do." Furthering creativity represents the constitutional, theoretical and doctrinal heart of patent law. Yet the field has not meaningfully evaluated the fundamental question of what creativity is. Using theories from psychology, sociology, history and the philosophy of science, this work examines and proposes how patent law can formulate a legal conception of creativity.

To undertake this inquiry, this work focuses on the U.S. Supreme Court's KSR International Co. v. Teleflex Inc. decision. When considering the appropriate standard for assessing nonobviousness under 35 U.S.C. § 103, the KSR Court used the phrase "ordinary creativity" to refer to the capabilities of the person of ordinary skill, a standard roughly analogous to tort law's reasonable person. KSR's choice of this phrase is intriguing, particularly because creativity as a human attribute is notoriously difficult to define. In order to provide a theoretical background that leads to an understanding of KSR's ordinary creativity standard, this work explores creativity from an interdisciplinary perspective. Further, the work proposes guidelines that may be used to implement KSR's flexible standard. More broadly, this work proposes that these interdisciplinary sources can be useful to the field's understanding of the process of invention.

I. INTRODUCTION	3
II. CREATIVITY'S RELEVANCE TO PATENT LAW	4
III. ORDINARY SKILL IN THE ART: HISTORY AND ORIGIN.....	8
A. <i>The Person of Ordinary Skill as a Central Figure in Patent Law</i>	8
B. <i>The Person of Ordinary Skill at the Inception of the U.S. Patent System</i>	11
C. <i>The Hotchkiss Nonobviousness Standard</i>	13
D. <i>The Post-Hotchkiss Person of Ordinary Skill</i>	14
E. <i>The 1952 Amendments to the Patent Act: Graham v. John Deere</i>	18
F. <i>Post-Graham Decision: In re Winslow</i>	19
G. <i>The Federal Circuit's PHOSITA as a Conventional Thinker</i>	21
H. <i>The Federal Circuit's Teaching-Suggestion-Motivation Test</i>	24
IV. KSR: EXPANDING THE PHOSITA'S CAPABILITIES	26
A. <i>Post-KSR: Scientific Creativity in the Courts</i>	29
B. <i>Post-KSR Nonobviousness: Complex Technologies</i>	30
V. TOWARD AN UNDERSTANDING OF SCIENTIFIC CREATIVITY	35
A. <i>How Scientists Think: The Psychology of Science</i>	37
B. <i>The Inventor as Genius</i>	42
C. <i>Scientific Creativity as the Exercise of Logic</i>	47
D. <i>Creativity as a Break from the Past</i>	53
1. <i>Insight and Creativity</i>	54
2. <i>Creativity and Chance: Invention as a Darwinian Process</i>	58
3. <i>Creativity as Cognition</i>	61
E. <i>The Socio-Cultural Context: Invention as a Social Process</i>	62
1. <i>When Lightning Strikes Twice</i>	62
2. <i>Simultaneous Inventions: Foundational Theories</i>	63
3. <i>Placing Multiples in Context</i>	65
4. <i>Scientific Advancement and Social Interaction</i>	67
VI. MEANINGFUL IMPLEMENTATION OF KSR: ORDINARY CREATIVITY	69
A. <i>KSR and Ordinary Creativity</i>	69
B. <i>Practical Implications of Creativity Research on the Nonobviousness Standard</i>	70
C. <i>Larger Implications for the Patent System</i>	76
VII. CONCLUSION	77

But what is the state of mind that is most propitious to the act of creation? I asked. Can one come by any notion of the state that furthers and makes possible that strange activity?

– Virginia Woolf, *A ROOM OF ONE'S OWN*

I. INTRODUCTION

The creation of new knowledge is perhaps the most complex human endeavor. The origins of a scientific advancement require one to move from a state of existing knowledge to create that which once seemed impossible. Such extraordinary thoughts are critical to intellectual and economic growth. The patent system is intended to encourage the creation of such knowledge. Despite this widely recognized goal, the field has not meaningfully engaged in exploring foundational concepts about scientific creativity.

The U.S. Supreme Court's decision in *KSR International Co. v. Teleflex Inc.* represents patent law's first effort to consider the origin of scientific thought.¹ As background, *KSR* considered nonobviousness, a patentability requirement that relies on the decision maker's conception of the problem-solving capabilities of the person of ordinary skill in the art.² In brief, the nonobviousness requirement holds that, if a hypothetical person skilled in the relevant domain could re-create the invention as a predictable variation of the state of the art, the patent claim is obvious and not worthy of patent protection.³ Loosely analogous to tort law's reasonable person, the person of ordinary skill had formerly been defined as one who applies domain-specific principles mechanistically. The *KSR* Court perceptibly shifted this definition, stating that "[a] person of ordinary skill is a person of ordinary creativity, not an automaton."⁴ The *KSR* Court's choice of the phrase "ordinary creativity" is intriguing, particularly because creativity as a human attribute is notoriously difficult to define.⁵

Infusing a hypothetical scientist or engineer with "ordinary creativity" interjects a phrase that lacks any source in either statutory or decisional law. Indeed, patent law has never attempted to define creativity in any context. On one hand, *KSR*'s "ordinary creativity" statement brings the hypothetical person of ordinary skill in the art closer to the mindset of those working in particular disciplines. On the other hand, the phrase's indeterminacy presents a challenge. Whether one is exercising ordinary creativity, or a patentable

1. 550 U.S. 398, 427 (2007).

2. *See id.* at 415-18.

3. *Id.* at 415-16.

4. *Id.* at 421.

5. *Id.*

level of creativity, is a new question in patent law and rests, to some degree, on an understanding about how scientists engage in breakthrough thinking.

The ordinary creativity standard was one component of *KSR*'s effort to ensure flexibility in assessing patentability. Because the term lacks an established definition, this work will consider conceptions of creativity from sources outside the law that have considered the phenomenon. Based on this research, an articulated understanding of ordinary creativity can be formulated by considering the problem type, the nature of the mental shift required to solve the problem and the social context in which the idea is generated can be formulated.

Beyond the nonobviousness standard, exploring the human act of invention has vital implications for intellectual property law. Fields examining the nature of the creative act agree, in large measure, that there are common attributes that exist across disciplines. Stated another way, the mental activity and societal framework that can lead to breakthroughs may not be materially different for artists and scientists. Probing the fundamental question of how we create illuminates a greater understanding of the intellectual property system, which is intended to foster creative thought and expression. In its current form, patent and copyright law's conception of creativity appears somewhat stilted against the rich background of interdisciplinary research that has studied the topic.

Part II considers the relevance of creativity in the legal sphere. Part III traces the history and doctrine of the person of ordinary skill to the manner in which *KSR* is implemented today. Part IV examines creativity research and literature, drawing on the fields of psychology, philosophy, history and sociology. Part V unites principles of law and interdisciplinary creativity research to demonstrate its application to the nonobviousness standard and the patent system more generally.

II. CREATIVITY'S RELEVANCE TO PATENT LAW

Over the past few centuries, patent law has developed rich and varied doctrines. The overwhelming majority of patent theory examines invention from perspectives that encompass the system as a whole. Law and economics offers theoretical perspectives that elucidate the operation of existing laws and animate proposals for change. Additionally, the success of the patent system has been increasingly evaluated from the perspective of firms.⁶ Indeed, the usefulness of the system is now examined according to the output of

6. See, e.g., Robert P. Merges, *One Hundred Years of Solicitude: Intellectual Property Law, 1900-2000*, 88 CAL. L. REV. 2187, 2216 (2000) (describing the impact of the "Corporatization of Industrial R&D"). "As the twentieth century progressed, inventions were more and more likely to be the product of large-scale corporate R&D rather than of the lone workshop tinkerer." *Id.*

entities;⁷ the importance of patent portfolio management has been recognized.⁸

Although these modes of examining the patent system are valuable, it is indisputable that patent law's existence centers on the inventive act of an individual.⁹ As economist Paul Romer recognized, "Technological advance comes from things that people do."¹⁰ Creativity represents the constitutional, theoretical and doctrinal heart of patent law. It is difficult to conceive how a legal system can foster creativity absent some understanding of what creativity is. Scientists and engineers perform the work that forms the bulk of the subject matter of the discipline. Understanding the process of invention assists, or at a minimum refrains from impeding, the incentive structure that the patent system was intended to create.¹¹ Further, examining how patentable

7. See, e.g., Clarisa Long, *Patent Signals*, 69 U. CHI. L. REV. 625 (2002) (suggesting a framework for the use of patents to signal positive information about firms in capital markets); FED. TRADE COMM'N, TO PROMOTE INNOVATION: THE PROPER BALANCE OF COMPETITION AND PATENT LAW AND POLICY 2 (2003), <http://www.ftc.gov/os/2003/10/innovationrpt.pdf> [hereinafter FTC REPORT] (The patent system "can enable firms to increase their expected profits from investments in research and development, thus fostering innovation that would not occur but for the prospect of a patent.").

8. See Michael J. Meurer & Katherine J. Strandburg, *Patent Carrots and Sticks: A Model of Nonobviousness*, 12 LEWIS & CLARK L. REV. 547, 548-49 (2008) (Meurer and Strandburg proposed a model of nonobviousness that assumes "that research projects are selected by a research manager, who evaluates the potential payoff of various approaches to a particular objective. Thus, we assume that the basic question confronting a researcher is not 'Shall I produce this invention?', but rather 'Which research path shall I pursue?'); Gideon Parchomovsky & R. Polk Wagner, *Patent Portfolios*, 154 U. PA. L. REV. 1, 6 (2005) ("The result is that the modern innovation environment exhibits (and requires) a high-volume, portfolio-based approach to the patent system . . .").

9. This point was considered in GREGORY J. FEIST, *THE PSYCHOLOGY OF SCIENCE AND THE ORIGINS OF THE SCIENTIFIC MIND* 31 (2006) [hereinafter *ORIGINS OF THE SCIENTIFIC MIND*].

Pretending that individuals are simply interchangeable pawns and to be understood only as players at the mercy of larger social and institutional forces with no individual differences to speak of is naive at best and dangerous at worst. Of course, individuals exist only in social groups, but to argue that an understanding of the psychological factors behind the individual is irrelevant is simply narrow and disciplinocentric . . .

Id.

10. Paul M. Romer, *The Origins of Endogenous Growth*, J. ECON. PERSP., Winter 1994, at 3, 12 (emphasis omitted) ("No economist, so far as I know, has ever been willing to make a serious defense of the proposition that technological change is literally a function of elapsed calendar time.").

11. Some examples of patent law doctrine that may benefit include experimental use, nonobviousness, the doctrine of equivalents and proper claim scope.

subject matter is created has the potential to illuminate whether the patent incentive structure is appropriately balanced.

Patent law invites consideration of the question of how new ideas are created.¹² The formulation and development of legal rules has the potential to affect real-world behaviors.¹³ Decisions made within this legal system are capable of promoting particular behaviors.¹⁴ Judgments underlying patent decisions should be cognizant of the inventive act as part of the calculus. Proceeding without pausing to inspect scientific creativity may result in the formulation of rules that do not optimally foster the precise type of activity that the system was intended to promote. At present, patent decision making has not formed a cohesive picture of scientific creativity or integrated meaningful reflection about the work performed by inventors into law.

For nonobviousness, the central issue is whether the claim states a sufficient advance over a solution that a person of ordinary skill would provide. If this hypothetical person can re-create the invention by making a predictable choice – that is, where successful results are readily apparent to such a person given the existing state of knowledge – such a choice does not support any need for a patent. On the other hand, the law recognizes that a patent is a proper incentive for advances that are unlikely to arise from the mind of the ordinarily skilled worker. Thus, nonobvious inventions warrant granting the right. To take a simplified example, a carpenter who assembles a chair using a nail rather than a screw, at a time when the woodworking arts recognize that either will predictably work, has employed an obvious solution, and no patent right is justified. On the other hand, Edison’s light bulb invention solved a longstanding problem with a solution that had eluded other researchers for years and represented a nonobvious solution for which a patent was warranted. To separate the patentable from the unpatentable, the person of ordinary skill construct compels consideration of facts underlying a “sufficiently creative” versus an “ordinarily creative” choice. This cannot be performed without understanding creativity.

Examining creativity is compelled by the Supreme Court’s opinion in *KSR*, which explicitly interjects “ordinary creativity” and “common sense” into the attributes of the person of ordinary skill in the art.¹⁵ Likewise, the

12. See, e.g., Dan L. Burk & Mark A. Lemley, *Policy Levers in Patent Law*, 89 VA. L. REV. 1575, 1674 (2003) (observing that the patent statute includes the opportunity for courts to exercise discretion to effectuate policy).

13. See generally, John R. Thomas, *Formalism at the Federal Circuit*, 52 AM. U. L. REV. 771, 801 (2003) (noting the impact of the public dedication rule on various arts and stating that “in particular the biotechnology industry has been heavily impacted”).

14. See, e.g., Arti K. Rai, *Engaging Facts and Policy: A Multi-Institutional Approach to Patent System Reform*, 103 COLUM. L. REV. 1035, 1110 (2003) (suggesting that the Federal Circuit’s jurisprudence reflects the interests of the patent bar).

15. *KSR Int’l Co. v. Teleflex, Inc.*, 550 U.S. 398, 421 (2007). Some prior cases indicate that the person of ordinary skill did not possess these attributes. For exam-

2006 *DyStar* decision by the U.S. Court of Appeals for the Federal Circuit began to introduce flexibility, stating that “[p]ersons of varying degrees of skill not only possess varying bases of knowledge, they also possess varying levels of imagination and ingenuity in the relevant field, particularly with respect to problem-solving abilities.”¹⁶ As recognized in *Abbott Laboratories v. Sandoz, Inc.*,

The evaluation of the choices made by a skilled scientist, when such choices lead to the desired result, is a challenge to judicial understanding of how technical advance is achieved in the particular field of science or technology. Such understanding is critical to judicial implementation of the national policy embodied in the patent statute.¹⁷

The human role in invention is central to whether an invention can be raised out of the realm of “ordinary creativity” or “common sense” for purposes of demonstrating nonobviousness.¹⁸ When the answer to this question is not evident, an understanding of how scientists interact with ideas is fundamental to distinguishing the patentable from the unpatentable.

Although the *KSR* and *DyStar* decisions introduce a welcome shift for the patent system, the introduction of the terms “creativity,” “common sense” and “imagination” creates indeterminacy. One may assume that these terms already have commonly understood meanings. For example, as Einstein stated, “[C]ommon sense is nothing more than a deposit of prejudices laid down in the mind before you reach eighteen.”¹⁹ However, once ensconced into a legal standard, applying these terms to concrete cases reveals that these terms are prone to vagueness and malleability. Given the widely varying experiences of decision makers, these words – so important to a conclusion of patentability – warrant a theoretical foundation to tether conclusions about patentability to a common theoretical understanding.

ple, the courts have described the person of ordinary skill as “presumed to be one who thinks along the line of conventional wisdom in the art and is not one who undertakes to innovate, whether by patient, and often expensive, systematic research or by extraordinary insights.” *Standard Oil Co. v. Am. Cyanamid Co.*, 774 F.2d 448, 454 (Fed. Cir. 1985).

16. *DyStar Textilfarben GmbH & Co. Deutschland KG v. C.H. Patrick Co.*, 464 F.3d 1356, 1370 (Fed. Cir. 2006).

17. 544 F.3d 1341, 1351-52 (Fed. Cir. 2008).

18. See generally *KSR Int'l Co.*, 550 U.S. at 421-22.

19. E.T. BELL, *MATHEMATICS: QUEEN AND SERVANT OF SCIENCE* 42 (1951) (quoting Albert A. Einstein).

III. ORDINARY SKILL IN THE ART: HISTORY AND ORIGIN

A. *The Person of Ordinary Skill as a Central Figure in Patent Law*

The phrase “person having ordinary skill in the art” (the “PHOSITA”) first appeared in the original U.S. Patent Act in 1790.²⁰ The standard has long been applied by the courts to assess the validity of an issued patent.²¹ Although the original statute used this objective standard to measure the sufficiency of an application’s disclosure, today, the role of the person of ordinary skill has grown to include other patent law doctrines, which can be loosely grouped into disclosure, novelty, statutory bar and nonobviousness questions.²²

20. Patent Act of 1790, ch. 7, § 2, 1 Stat. 109, 109-12 (1790) (outlining patent requirements, including one that the “specification shall be so particular, and said models so exact, as not only to distinguish the invention or discovery from other things before known and used, but also to enable a workman or other *person skilled in the art or manufacture*, whereof it is a branch, or wherewith it may be nearest connected, to make, construct, or use the same”) (emphasis added).

21. *See, e.g.*, *Woodworth v. Wilson*, 45 U.S. 712, 716 (1846) (applying the standard without extensive discussion); *Lowell v. Lewis*, 15 F. Cas. 1018, 1021 (C.C. Mass. 1817) (No. 8568) (charging jury, stating that “the question here is, and it is a question of fact, whether the specification be so clear and full, that a pump-maker of ordinary skill could, from the terms of the specification, be able to construct one upon the plan” of the patentee). The English system relied on a similar standard. *See Boulton v. Bull*, 126 Eng. Rep. 651 (1795).

22. *See Liquid Dynamics Corp. v. Vaughan Co.*, 449 F.3d 1209, 1224 (Fed. Cir. 2006) (discussing the doctrine of enablement); *Vas-Cath Inc. v. Mahurkar*, 935 F.2d 1555, 1563 (Fed. Cir. 1991) (“[T]he description must clearly allow persons of ordinary skill in the art to recognize that [he or she] invented what is claimed.” (quoting *In re Gosteli*, 872 F.2d 1008, 1012 (Fed. Cir. 1989)); *Minn. Mining & Mfg. Co. v. Chemque, Inc.*, 303 F.3d 1294, 1301 (Fed. Cir. 2002) (“For prior art to anticipate under 35 U.S.C. § 102(a) because it is ‘known,’ the knowledge must be publicly accessible, and it must be sufficient to enable one with ordinary skill in the art to practice the invention.”) (citations omitted); *Bayer AG v. Schein Pharm., Inc.*, 301 F.3d 1306, 1320 (Fed. Cir. 2002) (“[I]f the inventor subjectively considered one mode to be preferred over all others, then ‘[t]he second inquiry is whether the inventor’s disclosure is adequate to enable one of ordinary skill in the art to practice the best mode of the invention.’” (quoting *N. Telecom Ltd. v. Samsung Elec. Co.*, 215 F.3d 1281, 1286 (Fed. Cir. 2000)); *Union Pac. Res. Co. v. Chesapeake Energy Corp.*, 236 F.3d 684, 692 (Fed. Cir. 2001) (“The definiteness inquiry focuses on whether those skilled in the art would understand the scope of the claim when the claim is read in light of the rest of the specification.”); *Acromed Corp. v. Sofamor Danek Group, Inc.*, 253 F.3d 1371, 1380-81 (Fed. Cir. 2001) (activity which consisted of work that could be performed by one of ordinary skill in the art was insufficient to demonstrate that party was a joint inventor); *Graham v. John Deere Co.*, 383 U.S. 1, 14 (1966) (“Patentability is to depend, in addition to novelty and utility, upon the ‘non-obvious’ nature of the ‘subject matter sought to be patented’ to a person having ordinary skill in the perti-

One might suppose that patent doctrine has already developed a rich body of law that investigates the scientific process. That assumption is erroneous. There are opinions that discuss the nature of invention but only in the most general terms.²³ In fact, patent doctrine strongly discourages direct inquiry into the inventive activity surrounding a patent under examination and instead uses an objective standard.²⁴

For example, the statute governing nonobviousness provides that “[p]atentability shall not be negated by the manner in which the invention was made.”²⁵ In effect, this means that, for a nonobviousness decision, “neither the particular motivation nor the avowed purpose of the patentee controls”; rather “[w]hat matters is the objective reach of the claim.”²⁶ This section requires a comparison of an identified claim with the prior art. The patentee’s subjective experience is considered legally irrelevant to whether the claim’s advance over the prior art meets the nonobviousness standard.²⁷

ment art.” (quoting The Patent Act of 1952, ch. 950, § 103(a) (current version at 35 U.S.C. § 103(a)(2006))).

23. See, e.g., *KSR Int’l Co.*, 550 U.S. at 427 (“We build and create by bringing to the tangible and palpable reality around us new works based on instinct, simple logic, ordinary inferences, extraordinary ideas, and sometimes even genius. These advances, once part of our shared knowledge, define a new threshold from which innovation starts once more.”); *In re Bilski*, 545 F.3d 943, 1014 (Fed. Cir. 2008) (Rader, J., dissenting) (discussing the “elegance and simplicity” of solutions that are “the chief aims of all good science”), cert. granted, 129 S. Ct. 2735 (2009); *PharmaStem Therapeutics, Inc. v. ViaCell, Inc.*, 491 F.3d 1342, 1377-78 (Fed. Cir. 2007) (Newman, J., dissenting) (“The patent law recognizes that advances of great power may be based as much on persistent and skilled investigation as on the flash of creative genius, for both serve to transcend that which was previously achieved.”).

24. Although not directly analogous, this result parallels the doctrine of avoidance in copyright law, which precludes courts from making evaluations of artistic quality. See *Bleistein v. Donaldson Lithographing Co.*, 188 U.S. 239, 249-51 (1903) (Holmes, J.) (“It would be a dangerous undertaking for persons trained only to the law to constitute themselves final judges of the worth of pictorial illustrations”); Christine Haight Farley, *Judging Art*, 79 TUL. L. REV. 805, 807, 811 n.14 (2005) (describing “the view that legal and artistic determinations should not be merged and that judges should refrain from indulging in subjective aesthetic determinations”).

25. 35 U.S.C. § 103(a) (2006).

26. *KSR Int’l Co.*, 550 U.S. at 419. According to the Supreme Court, the section served “to abolish the test it believed this Court announced in the controversial phrase ‘flash of creative genius’” from nonobviousness jurisprudence. *Graham*, 383 U.S. at 15; see also 1952 Notes in Revision Notes & Legislative Reports accompanying 35 U.S.C. § 103 (This sentence was added to § 103 to preclude inquiry into whether an invention “resulted from long toil and experimentation or from a flash of genius.”).

27. See, e.g., *Purdue Pharma L.P. v. Endo Pharm. Inc.*, 438 F.3d 1123, 1132 (Fed. Cir. 2006) (“[T]he manner in which an invention is discovered, whether by insight or experiment, does not by itself affect patentability.”); *Life Techs., Inc. v. Clontech Labs., Inc.*, 224 F.3d 1320, 1325 (Fed. Cir. 2000) (“[T]he path that leads an inventor to the invention is expressly made irrelevant to patentability by statute.”); *In*

As one effect of this rule, patent law has not accumulated any dispositive rules based on actual inventive behavior. As another, decision makers are formally required to disregard a wealth of information about how inventions are actually developed. As a practical matter, this deflects consideration of the nature of breakthrough thinking that might require thorough examination if the rules were otherwise.

The doctrine of conception presents another opportunity for patent law to consider idea creation. This arises in two circumstances. First, conception is relevant to determine which party, between two or more disputing ones, was the first to invent and is thus entitled to a patent.²⁸ Second, one must establish conception to demonstrate that one is a joint inventor.²⁹ Conception is the mental act of an inventor who possesses a “definite and permanent idea of the complete and operative invention, as it is hereafter to be applied in practice.”³⁰ Additionally, an inventor must appreciate that the subject matter of this conception is inventive.³¹

Yet, in deciding cases, courts are not frequently forced to delve into an inventor’s subjective mental state. This is because a corroboration requirement, intended to alleviate concerns about testimonial bias, predominates the conception inquiry.³² Establishing conception requires the presentation of

re Kratz, 592 F.2d 1169, 1175 (C.C.P.A. 1979) (The “weight of the method appellant used in finding the invention is beside the point.”).

28. 35 U.S.C. § 102(g) (2006). *See also* Mahurkar v. C.R. Bard, Inc., 79 F.3d 1572, 1577 (Fed. Cir. 1996) (“[T]he person ‘who first conceives, and, in a mental sense, first invents . . . may date his patentable invention back to the time of its conception, if he connects the conception with its reduction to practice’” (quoting *Christie v. Seybold*, 55 F. 69, 76 (6th Cir. 1893))).

29. *Ethicon, Inc. v. U.S. Surgical Corp.*, 135 F.3d 1456, 1460 (Fed. Cir. 1998) (“Because ‘[c]onception is the touchstone of inventorship,’ each joint inventor must generally contribute to the conception of the invention.”) (quoting *Burroughs Wellcome Co. v. Barr Lab., Inc.*, 40 F.3d 1223, 1227-28 (Fed. Cir. 1994)).

30. *Hybritech Inc. v. Monoclonal Antibodies, Inc.*, 802 F.2d 1367, 1376 (Fed. Cir. 1986) (quoting *Coleman v. Dines*, 754 F.2d 353, 359 (Fed. Cir. 1985)). *See also* *Invitrogen Corp. v. Clontech Labs., Inc.*, 429 F.3d 1052, 1064 (Fed. Cir. 2005) (“[T]he court must identify when, during an emerging recognition that a particular invention includes something new, the inventor’s understanding reaches the level needed for appreciation.”). The inventor is required to appreciate that the idea is new as a factual matter but is not required to appreciate that the invention is patentable under the law. *See* *Dow Chem. Co. v. Astro-Valcour, Inc.*, 267 F.3d 1334, 1341 (Fed. Cir. 2001).

31. *See Hybritech*, 802 F.2d at 1376-78.

32. *See* *Chen v. Bourchard*, 347 F.3d 1299, 1309 (Fed. Cir. 2003) (deciding inventorship issue with reference to whether the corroboration requirement had been met, noting that the corroboration requirement “addresses the concern that a party claiming inventorship might be tempted to describe his actions in an unjustifiably self-serving manner in order to obtain a patent or to maintain an existing patent”); *Kridl v. McCormick*, 105 F.3d 1446, 1450 (Fed. Cir. 1997) (“[T]he purpose of corroboration . . . is to prevent fraud, by providing independent confirmation of the inven-

objective, independent evidence of the inventor's mental act.³³ This rule "provides a bright line for both district courts and the PTO [(U.S. Patent & Trademark Office)] to follow in addressing the difficult issues related to invention dates."³⁴ This evidence, assessed under a rule of reason test, may include records created contemporaneously with conception, non-inventor testimony or other circumstantial evidence.³⁵ In many cases, whether conception exists turns on an analysis of the sufficiency and quality of such evidence.³⁶ Indeed, an inventor's own testimony concerning invention is viewed with skepticism.³⁷

The doctrines that avoid direct inquiry into an inventor's mental state were instituted for sound policy reasons. At the same time, the dispositive issues most reliant on the inventive act do not turn on examination of subjective idea generation by an actual inventor. Consequently, patent law has not developed a rich factual basis upon which an understanding of scientific creativity can be built. Even if the rules were otherwise, scant theoretical development of the inventive process has been developed in the law.

B. The Person of Ordinary Skill at the Inception of the U.S. Patent System

A number of early U.S. decisions considered the person of ordinary skill standard in assessing whether a patent specification adequately described the invention and, thereby, met the enablement standard.³⁸ These early decisions

tor's testimony."); *Medichem, S.A. v. Rolabo, S.L.*, 437 F.3d 1157, 1170 (Fed. Cir. 2006) (The court applied a requirement for independent evidence as corroboration of inventorship, stating, "[T]he corroboration requirement provides an additional safeguard against courts being deceived by inventors who may be tempted to mischaracterize the events of the past through their testimony.").

33. *Invitrogen Corp.*, 429 F.3d at 1065.

34. *Mahurkar v. C.R. Bard, Inc.*, 79 F.3d 1572, 1577 (Fed. Cir. 1996).

35. *Checkpoint Sys., Inc. v. All-Tag Sec. S.A.*, 412 F.3d 1331, 1339 (Fed. Cir. 2005).

36. *See, e.g., Gemstar-TV Guide Int'l, Inc. v. Int'l Trade Com'n*, 383 F.3d 1352, 1381-83 (Fed. Cir. 2004) (finding corroborating evidence insufficient to establish inventorship); *Brown v. Barbacid*, 276 F.3d 1327, 1336-37 (Fed. Cir. 2002) (reversing decision based on a failure to examine relevant corroborating testimony relating to conception).

37. *Price v. Symsek*, 988 F.2d 1187, 1194 (Fed. Cir. 1993) ("[A]n inventor's testimony, standing alone, is insufficient to prove conception – some form of corroboration must be shown.").

38. Generally, a patent specification must enable a person of ordinary skill in the art to make and use the invention. *See* 35 U.S.C. § 112 (2006). As one court described, "Patent protection is granted in return for an enabling disclosure of an invention, not for vague intimations of general ideas that may or may not be workable." *Genentech, Inc. v. Novo Nordisk A/S*, 108 F.3d 1361, 1366 (Fed. Cir. 1997). The person of ordinary skill has been central to the enablement assessment since the earli-

did not assess nonobviousness as that doctrine currently exists. Prior to 1850, a growing, although intermittent, judicial understanding began to emerge that something more than novelty and usefulness should be required to obtain a patent.³⁹

These early cases considered novelty as a doctrine that is broader than our modern novelty standard.⁴⁰ More specifically, novelty under current law requires “strict identity” – that is, an invalidating reference must contain the identical subject matter of an inventor’s claim.⁴¹ For example, a chair assembled using nails cannot invalidate a patent claim for a chair assembled using wood screws because the two differ in that one minor detail and, therefore, are not strictly identical. This is true even where the claim under examination is substantially similar to, and a nonobvious variant of, a work already existing in the prior art.

Under modern law, where strict identity is lacking, a claim is examined under nonobviousness. By contrast, courts in the early 1800s invalidated patents under a “substantial novelty” standard. Under this rule, only patents that embodied “a different principle” or a difference in the “structure, operation, effect or efficiency that would tend to show that the invention was more than a ‘colorable variation’ of the prior art were held valid.”⁴² As one exam-

est days of the U.S. patent system. *See, e.g.*, *Park v. Little*, 18 F. Cas. 1107, 1108 (C.C.D. Pa. 1813) (No. 10,715) (charging the jury as to the sufficiency of the specification, “so as to enable any person skilled in the art of which it is a branch, or with which it is most nearly connected, to make and use the same”); *Gray v. James*, 10 F. Cas. 1015, 1018 (C.C.D. Pa. 1817) (No. 5718) (“The law declares that it must be full, clear, and explicit, so as to distinguish it from all other machines of the same kind, and to enable any person skilled in the art, of which it is a branch, to make and use the same.”).

39. *See generally* John F. Duffy, *Inventing Invention: A Case Study of Legal Innovation*, 86 TEX. L. REV. 1 (2007) (tracing the development of the nonobviousness doctrine in U.S. law). “[E]ven before the middle of the nineteenth century, U.S. courts began to look to obviousness as at least one element in defining the concept of a ‘change in principle’ that had become a precondition for patentability.” *Id.* at 38.

40. *See* Kenneth J. Burchfiel, *Revising the “Original” Patent Clause: Pseudo-history in Constitutional Construction*, 2 HARV. J.L. & TECH. 155, 191 (1989) (“Novelty is a significantly narrower concept in modern patent law than under the first patent acts.”).

41. In patent law, a “reference” is evidence that a particular claim is invalid for failure to meet the novelty or nonobviousness requirement. As one example, Edison’s 1880 patent to a light bulb acts as a reference to prevent later attempts to patent the identical bulb or obvious variations of Edison’s invention.

Under the current “strict identity” novelty standards, a prior art reference must disclose every element of the subject claim either expressly or through the doctrine of inherency. *EMI Group N. Am., Inc. v. Cypress Semiconductor Corp.*, 268 F.3d 1342, 1350 (Fed. Cir. 2001) (stating rule).

42. Burchfiel, *supra* note 40, at 193-94 (footnotes omitted). Burchfiel notes that courts in this era developed a “substantial novelty” standard that paralleled the doctrine of equivalents. *Id.* at 193 (“Applying the maxim, ‘that which infringes if later,

ple, the 1814 case of *Odiorne v. Winkley*, authored by Justice Story, applied a broadened novelty principle in a jury instruction that stated that prior art may invalidate a claim if “constructed substantially upon the same principles, and upon the same mode of operation.”⁴³ This view was echoed by the Supreme Court’s 1822 decision, *Evans v. Eaton*, which indicated that inventions are not patentable in light of prior art “[i]f they were the same in principle, and merely differed in form and proportion.”⁴⁴ Similarly, Story’s 1845 ruling in *Allen v. Blunt* pointed out that, “upon the question of the novelty of an invention,” expert testimony could be considered to “ascertain whether the mechanical apparatus or chemical compound was identical in its composition and structure or not, or whether the differences consisted in the mere change of one known mechanical equivalent for another.”⁴⁵

These early cases did not rely on the person of ordinary skill as the benchmark.⁴⁶ Indeed, Justice Story’s opinion in *Earle v. Sawyer*, in 1825, explicitly rejected the argument that a patent should only be granted for an invention that is beyond the capabilities of one skilled in the relevant art.⁴⁷ In *Earle*, the court noted that the defendant’s proposal introduced a “mode of reasoning upon [a] metaphysical nature, or the abstract definition of an invention,” at odds with the Patent Act,⁴⁸ which Story explained had been written “upon the language of common sense and common life, and ha[d] nothing mysterious or equivocal in it.”⁴⁹ That interpretation of the Patent Act was soon to irreversibly change.

C. The Hotchkiss Nonobviousness Standard

A breaking point occurred in 1848, when a federal trial court used the knowledge of those of skill in the art as the baseline for determining patent-

anticipates if earlier,’ the courts developed a unitary equivalents standard that was applied to questions of both infringement and novelty . . .” (footnote omitted).

43. 18 F. Cas. 581, 582 (C.C.D. Mass. 1814) (No. 10,432). See also *Allen v. Blunt*, 1 F. Cas. 448, 450 (C.C.D. Mass. 1845) (No. 216).

44. 20 U.S. 356, 431 (1822).

45. 1 F. Cas. at 450.

46. See Edward C. Walterscheid, *The Hotchkiss Unobviousness Standard: Early Judicial Activism in the Patent Law*, 13 J. INTELL. PROP. L. 103, 115 (2005) (With respect to court decisions under the Patent Act of 1793, “the level of skill in the particular art was not addressed, and hence a critical component of the modern unobviousness standard was missing.”).

47. 8 F. Cas. 254, 255-56 (C.C.D. Mass. 1825) (No. 4247).

48. The version of the Patent Act relied upon by the *Earle* court was the Patent Act of 1793, which stated that a patent would be issued for “any new and useful” invention that was “not known or used before the application.” Patent Act of 1793, ch. 11 § 1, 1 Stat. 318, 319 (1793).

49. *Earle*, 8 F. Cas. at 255.

bility in *Hotchkiss v. Greenwood*.⁵⁰ The patent in suit was directed to an improvement for making knobs for doors or furniture by attaching clay or porcelain to a metal shank and spindle using a dovetail and screw configuration.⁵¹ The *Hotchkiss* trial court instructed the jury that, if “no other ingenuity or skill [was] necessary to construct the knob than that of an ordinary mechanic acquainted with the business, the patent [was] void and the plaintiffs [were] not entitled to recover.”⁵² After the jury found for the accused infringer, the patentee sought review before the Supreme Court.⁵³

The Supreme Court’s decision in *Hotchkiss v. Greenwood* adopted the standard used by the lower court, finding the patent was invalid for “an absence of that degree of skill and ingenuity which constitute essential elements of every invention.”⁵⁴ In *Hotchkiss*, the Court observed that none of the knob’s individual components was new and that the differences between the patent and pre-existing solutions were merely “formal, and destitute of ingenuity or invention.”⁵⁵ Under *Hotchkiss*, a patent is not granted for the result of the “judgment and skill in the selection and adaptation of the materials” that were merely “the work of the skilful mechanic, not that of the inventor.”⁵⁶ The Supreme Court placed this construct into the law without any extensive definition. As Professor John Duffy recognized, this portion of the *Hotchkiss* opinion is “terribly ambiguous.”⁵⁷ Although the hypothetical person was defined as possessing a baseline level of “ingenuity and skill,”⁵⁸ these terms are hardly self-defining. Over the next several decades, courts endeavored to fill in this vacuum with terminology that ultimately veered significantly off course from its origin.

D. *The Post-Hotchkiss Person of Ordinary Skill*

Over the next several years, courts interpreted the statement in *Hotchkiss* that an improvement is not patentable when it reflects the “work of a skilful mechanic, not that of the inventor”⁵⁹ as a patentability prerequisite.⁶⁰

50. 12 F. Cas. 551 (C.C.D. Oh. 1848) (No. 6718).

51. *Id.* at 551.

52. *Id.* at 553.

53. *Id.*

54. 52 U.S. 248, 267 (1850). All discussion of the *Hotchkiss* decision in the remainder of this Article refers to the U.S. Supreme Court’s opinion in the case.

55. *Id.* at 266.

56. *Id.* at 266-67.

57. Duffy, *supra* note 39, at 40 (describing differing interpretations of this standard).

58. *Hotchkiss*, 52 U.S. at 267.

59. *Id.*

60. See Honorable Giles S. Rich, The Vague Concept of “Invention” as Replaced by § 103 of the 1952 Patent Act, Kettering Award Acceptance Speech, in 46 J. PAT.

Courts called this the “requirement for invention,” a standard that later evolved into the modern nonobviousness standard.⁶¹ Under its terms, claims warranting patent protection were viewed as delivering a “mental result”⁶² or the work of “the peculiar intuitive genius which is a characteristic of great inventors.”⁶³ Inventions that failed to meet this standard were found unpatentable as merely the result of efforts of the person of ordinary skill.

Fundamentally, *Hotchkiss* required an advance in an art beyond existing solutions based on information obtainable at the time of invention, using the person of ordinary skill as a proxy.⁶⁴ For example, the Supreme Court’s 1876 decision in *Smith v. Goodyear Dental Vulcanite Co.* considered the validity of a patent directed to the construction of artificial teeth using rubber rather than gold, which was used in the prior art.⁶⁵ Arguably, the *Smith* patent was nothing more than the substitution of one material for another and therefore not patentable under *Hotchkiss*. Yet the *Smith* Court noted that this substitution was a technical advance in the art, explaining that “[a] new product was the result, differing from all that had preceded it, not merely in degree of usefulness and excellence, but differing in kind, having new uses and properties.”⁶⁶ In *Smith*, the Court coupled the mechanical merit with the person of ordinary skill, stating, “These differences, in our opinion, are too many and too great to be ascribed to mere mechanical skill. They may justly be regarded as the results of inventive effort, and as making the manufacture of which they are attributes a novel thing in kind, and consequently patentable as such.”⁶⁷

Likewise, the *C. & A. Potts & Co. v. Creager* Court considered the patentability of a device that relied on a grooved cylinder to break up hard clay.⁶⁸ The patent was challenged on the ground that similarly shaped cylinders had been employed in a prior art device used to polish wood.⁶⁹ In *Potts*, the Court found the analogy between the uses of the two devices too remote for a person of ordinary skill to implement and found that the patent was the product “of the exercise of the inventive faculty” and therefore valid.⁷⁰ As the Court described,

Indeed, it often requires as acute a perception of the relations between cause and effect, and as much of the peculiar intuitive ge-

OFF. SOC’Y 855, 860 (1964), *reprinted in* 14 FED. CIR. B.J. 147, 155 (2004) (subsequent citations will be to the reprinted version).

61. *Id.* at 157.

62. *Smith v. Nichols*, 88 U.S. 112, 118 (1874).

63. *C. & A. Potts & Co. v. Creager*, 155 U.S. 597, 607-08 (1895).

64. 52 U.S. at 266.

65. 93 U.S. 486, 486 (1876).

66. *Id.* at 494.

67. *Id.* at 497.

68. 155 U.S. 597, 601-02 (1895).

69. *Id.* at 600, 604, 606.

70. *Id.* at 606, 609.

nus which is a characteristic of great inventors, to grasp the idea that a device used in one art may be made available in another, as would be necessary to create the device de novo.⁷¹

In contrast, courts found that solutions derived from the “natural[] suggest[ion]” of information in the prior art did not meet the invention requirement.⁷² For example, in *Sinclair*, the Supreme Court invalidated a patent claim to a fast-drying ink that relied on common solvents selected from a catalogue.⁷³ *Sinclair* described this activity as “no more ingenious than selecting the last piece to put into the last opening in a jig-saw puzzle.”⁷⁴ Such cases considered the mental act of invention as determinative when implementing *Hotchkiss*.

Treatment of the invention standard was not uniform. For example, some courts invoked principles akin to the former substantial novelty standard, finding that an invention that represented “a change only in form, proportions, or degree,” was merely “the substitution of equivalents” and did not support patent protection.⁷⁵ Objective indicia of nonobviousness were emphasized in some decisions.⁷⁶ Nonetheless, many courts considered the determinative distinction to be between ordinary skill and “an operation of the intellect, . . . a product of intuition, or of something akin to genius.”⁷⁷ A number of Supreme Court cases tracked this two-tiered construct during this era.⁷⁸ Yet the *McClain v. Ortmyer* Court acknowledged that this articulation

71. *Id.* at 607-08.

72. *See, e.g.,* *Day v. Fair Haven & W. Ry. Co.*, 132 U.S. 98, 102 (1889); *Ohmer Fare Register Co. v. Ohmer*, 238 F. 182, 186 (6th Cir. 1916).

73. *Sinclair & Carroll Co. v. Interchemical Corp.*, 325 U.S. 327, 334-35 (1945).

74. *Id.* at 335; *see also* *Brown v. Piper*, 91 U.S. 37, 41 (1875) (finding that a claim for the use of cold air to preserve fish “was simply the application by the patentee of an old process to a new subject, without any exercise of the inventive faculty”).

75. *Smith v. Nichols*, 88 U.S. 112, 119 (1874).

76. *See* *Smith v. Goodyear Dental Vulcanite Co.*, 93 U.S. 486, 494 (1876); *Expanded Metal Co. v. Bradford*, 214 U.S. 366, 381 (1909) (“[I]f those skilled in the mechanical arts are working in a given field, and have failed, after repeated efforts, to discover a certain new and useful improvement, that he who first makes the discovery has done more than make the obvious improvement which would suggest itself to a mechanic skilled in the art . . .”).

77. *McClain v. Ortmyer*, 141 U.S. 419, 426-27 (1891).

78. *See* *Reckendorfer v. Faber*, 92 U.S. 347, 356-57 (1875) (“The distinction between mechanical skill, with its conveniences and advantages and inventive genius, is recognized in all the cases.”); *Concrete Appliances Co. v. Gomery*, 269 U.S. 177, 185 (1925) (referring to “the product only of ordinary mechanical or engineering skill and not of inventive genius”); *Smith v. Whitman Saddle Co.*, 148 U.S. 674, 679 (1893) (“Mere mechanical skill is insufficient. There must be something akin to genius, – an effort of the brain as well as the hand.”); *Phillips v. City of Detroit*, 111 U.S. 604, 607 (1884) (patent was invalid where “[i]t involve[d] merely the skill of the workman and not the genius of the inventor”); *Watson v. Cincinnati, Indianapolis, St.*

was nebulous, acknowledging that “the word [invention] cannot be defined in such manner as to afford any substantial aid in determining whether a particular device involves an exercise of the inventive faculty or not.”⁷⁹

Despite the *McClain* Court’s recognition of the ambiguity of the standard, a distinction between mechanical skill, on one hand, and “the result of the exercise of the creative faculty,”⁸⁰ or “something akin to genius,”⁸¹ on the other, established deep roots in nonobviousness jurisprudence. The strongest statement in this vein was the Supreme Court’s 1941 ruling in *Cuno Engineering Corp. v. Automatic Devices Corp.*, where the Court stated that a claim “must reveal the flash of creative genius” to meet the invention standard.⁸² *Cuno*’s requirement that a patent evidence “creative genius” was intended to guard against the grant of patents for trivial inventions.⁸³ As the *Cuno* Court explained, “Strict application of that test is necessary lest in the constant demand for new appliances the heavy hand of tribute be laid on each slight technological advance in an art.”⁸⁴

Ultimately, *Cuno*’s flash of creative genius standard proved indeterminate and entirely unworkable as a legal standard.⁸⁵ As Justice Learned Hand stated, the invention standard had become “as fugitive, impalpable, wayward, and vague a phantom as exi[st]s in the whole paraphernalia of legal concepts.”⁸⁶ A lack of uniformity led a National Patent Planning Commission, appointed by President Roosevelt, to report that “[t]he most serious weakness in the present patent system is the lack of a uniform test or standard for determining whether the particular contribution of an invention merits the award of the patent grant.”⁸⁷ The Commission’s report identified that the standard applied in the courts diverged from that applied in the U.S. Patent Office.⁸⁸ At least one commentator observed that courts used the invention requirement

Louis & Chicago Ry. Co., 132 U.S. 161, 167 (1889) (invalidating patent where the asserted invention “may have required some mechanical skill, and may have been new and useful, but it did not involve the exertion of the inventive faculty”).

79. 141 U.S. at 426-27.

80. *Expanded Metal Co. v. Bradford*, 214 U.S. 366, 381 (1909).

81. *McClain*, 141 U.S. at 427.

82. *Cuno Engineering Corp. v. Automatic Devices Corp.*, 314 U.S. 84, 91 (1941).

83. *Id.* at 91-92.

84. *Id.* at 92.

85. *See, e.g., Deering Milliken Research Corp. v. Elec. Furnace Corp.*, 261 F.2d 619, 621 (6th Cir. 1958) (noting that the “‘flash of creative genius’ test may not have proved too useful a solution of the problem of patentability”).

86. *Harries v. Air King Prods. Co.*, 183 F.2d 158, 162 (2d Cir. 1950).

87. NAT’L PATENT PLANNING COMM’N, *THE AMERICAN PATENT SYSTEM* (1943), reprinted in 25 J. PAT. OFF. SOC’Y 455, 462 (subsequent citations will be to the reprinted version).

88. *Id.* (“There is an ever widening gulf between the decisions of the Patent Office in granting patents and decisions of the courts who pass on their validity.”).

to inject their views about patents into validity decisions.⁸⁹ Indeed, U.S. Supreme Court Justice Jackson, in a dissent written in 1949, referred to the “strong passion in this Court for striking [patents] down so that the only patent that is valid is one which this Court has not been able to get its hands on.”⁹⁰

In 1952, the Patent Act was amended to add section 103, which eschews use of the term “invention” in favor of “nonobviousness.”⁹¹ In addition, section 103 expressly embeds the person of ordinary skill into the nonobviousness test.⁹² Specifically, section 103 provides that no patent may describe subject matter that “as a whole would have been obvious at the time the invention was made to a person having ordinary skill in the art to which said subject matter pertains.”⁹³

E. The 1952 Amendments to the Patent Act: Graham v. John Deere

The 1966 *Graham v. John Deere Co.* decision presented the Supreme Court with its first opportunity to elucidate the meaning of section 103.⁹⁴ The *Graham* Court expressly discounted references to inventive genius as the proper standard, calling such characterizations mere “rhetorical embellishment of language.”⁹⁵ After rejecting *Cuno*, the *Graham* Court excavated *Hotchkiss* and its progeny as the benchmark for nonobviousness under section 103.⁹⁶ That is, *Graham* found that section 103 codified the century-old *Hotchkiss* invention standard, both in the mode of analysis and in the level of breakthrough necessary to obtain a patent.⁹⁷ Thus, *Hotchkiss*’s reliance on the intellectual capability of the person of ordinary skill remains the critical foundation for this core patentability requirement.

89. Hon. Giles S. Rich, *Laying the Ghost of the “Invention” Requirement*, 1 AM. PAT. L. ASS’N Q.J. 26, 31 (1972) (stating that the invention standard “became the plaything of the judiciary and many judges delighted in devising and expounding their own ideas of what it meant”).

90. *Jungersen v. Ostby & Barton Co.*, 335 U.S. 560, 572 (1949) (Jackson, J., dissenting).

91. The Patent Act of 1952, ch. 950, § 103 (current version at 35 U.S.C. § 103 (2006)).

92. 35 U.S.C. § 103(a).

93. *Id.*

94. 383 U.S. 1, 3 (1966).

95. *Id.* at 15.

96. *Id.* at 17.

97. *Id.* at 3-4 (“We have concluded that the 1952 Act was intended to codify judicial precedents embracing the principle long ago announced by this Court in *Hotchkiss* . . . , and that, while the clear language of s[ection] 103 places emphasis on an inquiry into obviousness, the general level of innovation necessary to sustain patentability remains the same.” (citation omitted)).

In *United States v. Adams*, decided the same day as *Graham*,⁹⁸ the Supreme Court elaborated on the characteristics of the person of ordinary skill within the nonobviousness framework. The *Adams* patent claimed a battery that could be activated with the addition of water.⁹⁹ Nearly all elements of the claim were scattered throughout the relevant prior art.¹⁰⁰ The *Adams* Court found the patent nonobvious, underscoring that a person of ordinary skill would have been deterred from pursuing the claimed invention because the art suggested that the device was neither practical nor likely to operate.¹⁰¹ That is, an inventor earned a patent by overcoming a “paper tiger” that “taught away” from the claimed invention.¹⁰² *Graham* and *Adams* reconfirmed the link between a technological advance and a hypothetical recreation of the inventive act by one of ordinary skill.

F. Post-Graham Decision: In re Winslow

Post-*Graham*, the lower courts considered the ordinary skill inquiry and derived a number of diverse approaches. In 1966, the Court of Custom and Patent Appeals decided *In re Winslow*, just months after *Graham* was issued.¹⁰³ *Winslow* was an effort to articulate more fully that a patent based on prior art is assessed using a hypothetical replication of the act of invention. *Winslow* involved an appeal of the rejection of claims describing a packaging device.¹⁰⁴ The described machine included a stack of bags lying horizontally, held in place with pins that went through punctures on flaps on the bags.¹⁰⁵ A jet of air was used to open the uppermost bag so that items could be inserted.¹⁰⁶ The patent office’s rejection relied on a patent by Hellman, which disclosed a machine for filling bags held vertically by the use of a rod.¹⁰⁷ A prior art patent, invented by an individual named Gerbe, tracked the *Winslow* application except for the use of clamps and the use of a stop rather than a rod to hold the bags in place.¹⁰⁸ Affirming the rejection, the *Winslow* Court in-

98. 383 U.S. 39, 39 (1966).

99. *Id.* at 42-43.

100. *Id.* at 45-49.

101. *Id.* at 51-52.

102. The term “paper tiger” is a useful image used in *Pozzoli SPA v. BDMO SA*, [2007] EWCA Civ 588, [2007] FSR, 37 a United Kingdom decision applying the parallel “inventive concept” requirement to patentability. As the court in *Pozzoli* described, “A patentee who contributes something new by showing that, contrary to the mistaken prejudice, the idea will work or is practical has shown something new. He has shown that an apparent ‘lion in the path’ is merely a paper tiger.” *Id.*

103. 365 F.2d 1017, 1017 (C.C.P.A. 1966).

104. *Id.*

105. *Id.* at 1017-18.

106. *Id.*

107. *Id.* at 1018-19.

108. *Id.*

structed that nonobviousness should be assessed by “pictur[ing] the inventor as working in his shop with the prior art references – which he is presumed to know – hanging on the walls around him.”¹⁰⁹ The *Winslow* opinion describes a hypothetical reconstruction of the claim:

If there were any bag holding problem in the Gerbe machine when plastic bags were used, their flaps being gripped only by spring pressure between the top and bottom plates, Winslow would have said to himself, “Now what can I do to hold them more securely?” Looking around the walls, he would see Hellman’s envelopes with holes in their flaps hung on a rod. He would then say to himself, “Ha. I can punch holes in my bags and put a little rod (pin) through the holes. That will hold them. After filling the bags, I’ll pull them off the pins as does Hellman.”¹¹⁰

Of all patent opinions, *Winslow* offers one of the most detailed accounts of the supposed inventive process by one of ordinary skill. Yet therein lies indeterminacy. Under *Winslow*, an inference triggered by the inspiration drawn from the prior art can result in an invalid patent.¹¹¹ In *Winslow*, sources of potential answers to the problem to be solved were figuratively surrounding the person of ordinary skill, who works in a logical manner to implement a solution. However, what *Winslow* cannot possibly describe is any recipe for extending this analysis to the full range of inventive scenarios. Additionally, a court or a jury must imagine this reconstruction without any background in inventive processes or, for that matter, the processes used by those of ordinary skill. As Professor Thomas recognized, “The difficulty with the *Winslow* image, however compelling and readily visualized, is that it provided no precise guidelines on how a person of skill in the art would unite disparate teachings from the prior art in order to achieve the claimed combination.”¹¹² This gap is not trivial. According to the governing statute, the hypothetical person plays a key role in this foundational patentability doctrine.¹¹³

109. *Id.* at 1020.

110. *Id.*

111. See also *In re Antle*, 444 F.2d 1168, 1171-72 (C.C.P.A. 1971) (Section 103 “requires us to presume that the inventor would have that ability to select and utilize knowledge from other arts reasonably pertinent to his particular problem which would be expected of a man of ordinary skill in the art to which the subject matter pertains.”).

112. John R. Thomas, *Formalism at the Federal Circuit*, 52 AM. U. L. REV. 771, 790 (2003).

113. See *id.* at 789 (Nonobviousness is a “fundamental gatekeeper to patenting.”); ROBERT PATRICK MERGES & JOHN FITZGERALD DUFFY, *PATENT LAW AND POLICY* 611 (4th ed. 2007) (Many patent lawyers consider nonobviousness the most important of the basic patent requirements; it has been called “the ultimate condition of patentabili-

After *Graham* and *Winslow* were decided, and prior to the formation of the Federal Circuit, courts – including all of the circuit courts that were deciding patent cases during this time – endeavored to implement section 103. Some examined the education and experience level of those working in the relevant art.¹¹⁴ Only one court, the Ninth Circuit, considered that the person of ordinary skill was capable of creativity.¹¹⁵ Specifically, that court noted that nonobviousness depended “in part upon the degree of creativity one having ordinary skill in the art would need to exercise in arriving at the same new idea” and opined that “less creative thought” was needed to eliminate a step compared to adding one.¹¹⁶ Any precedential value of these circuit court opinions disappeared in 1982 when the Federal Circuit was formed.¹¹⁷

G. The Federal Circuit’s PHOSITA as a Conventional Thinker

After its formation in 1982, the Court of Appeals for the Federal Circuit defined the person of ordinary skill in terms of education and experience level in a relevant field.¹¹⁸ Adopting the rule developed in its predecessor court,¹¹⁹ the Federal Circuit considered the following factors relevant to determining the level of one of ordinary skill: “(1) the educational level of the inventor; (2) type of problems encountered in the art; (3) prior art solutions to those problems; (4) rapidity with which innovations are made; (5) sophistication of the technology; and (6) educational level of active workers in the field.”¹²⁰

ty.” (citing *NONOBVIOUSNESS – THE ULTIMATE CONDITION OF PATENTABILITY* (John F. Witherspoon, ed.1980)).

114. *See, e.g., Kistler Instrumente AG v. United States*, 628 F.2d 1303, 1317 (Ct. Cl. 1980); *Great Lakes Stamp & Mfg. Co. v. Reese Finer Foods, Inc.*, 402 F.2d 346, 351 (7th Cir. 1968); *Stevenson v. Grentec, Inc.*, 652 F.2d 20 (9th Cir. 1981); *Smith v. ACME General Corp.*, 614 F.2d 1086, 1094 (6th Cir. 1980).

115. *Westinghouse Elec. Corp. v. Titanium Metals Corp.*, 454 F.2d 515, 518 (9th Cir. 1971).

116. *Id.*

117. *See, e.g., SmithKline Beecham Corp. v. Apotex Corp.*, 403 F.3d 1331, 1353 (Fed. Cir. 2005) (referring to decisions of “our sister circuits, whose rulings on patent law prior to 1982 do not bind this court but retain persuasive value”).

118. *See, e.g., Raytheon Co. v. Roper Corp.*, 724 F.2d 951, 960-61 (Fed. Cir. 1983); *Medtronic, Inc. v. Cardiac Pacemakers, Inc.*, 721 F.2d 1563, 1572 (Fed. Cir. 1983).

119. *See, e.g., Stratoflex, Inc. v. Aeroquip Corp.*, 713 F.2d 1530, 1538 (Fed. Cir. 1983) (adopting considerations stated in *Jacobson Bros., Inc. v. United States*, 512 F.2d 1065, 1071 (Ct. Cl. 1975)); *Orthopedic Equip. Co., Inc. v. United States*, 702 F.2d 1005, 1011 (Fed. Cir. 1983) (also adopting *Jacobson Bros., Inc.*, 512 F.2d at 1071).

120. *Envtl. Designs, Ltd. v. Union Oil Co.*, 713 F.2d 693, 696 (Fed. Cir. 1983). According to *Environmental Design*, the test is applied flexibly. *Id.* at 696-96. Thus, “[n]ot all such factors may be present in every case, and one or more of these or other factors may predominate in a particular case.” *Id.*

As with the prior conceptions of the person of ordinary skill, this construct was intended to provide objectivity in the nonobviousness inquiry.¹²¹ The test does not explicitly reference common sense, reasoning or problem-solving abilities.¹²² At one time, the Federal Circuit's jurisprudence even appeared to foreclose the possibility that one of ordinary skill possessed creativity. In the 1985 case *Standard Oil Co. v. American Cyanamid Co.*, the court explained that this hypothetical person was "presumed to be one who thinks along the line of conventional wisdom in the art and is not one who undertakes to innovate."¹²³

Pre-*KSR*, a PHOSITA in some Federal Circuit decisions had the ability to draw some modest logical inferences. Two cases involving simple technology illustrate this. In *Brown & Williamson Tobacco Corp. v. Philip Morris Inc.*, the Federal Circuit considered the validity of a patent directed to cigarette design.¹²⁴ The patent claimed a narrower circumference than those in the prior art.¹²⁵ The *Brown & Williamson* court affirmed a determination of invalidity, finding "overwhelming evidence of obviousness, particularly in light of the relatively small difference between the prior art . . . cigarette and the claimed invention, and the high degree of skill for the ordinary artisan."¹²⁶ The *In re Huang* decision considered whether claims to a tennis racquet grip were nonobvious.¹²⁷ Generally, prior art grips used two layers; one primarily absorbed shock.¹²⁸ According to the opinion, the claimed grip differed from the prior art only by an increased thickness of the shock-absorbing layer.¹²⁹ Finding the invention obvious, the court explained that the person of ordinary skill would "logically infer that increasing the amount of the shock absorbing material would . . . increase . . . shock absorption."¹³⁰

In contrast, in *Al-Site Corp. v. VSI International, Inc.*, the boundaries of the inferences that a PHOSITA could draw were remarkably narrow.¹³¹ There, an infringer asserted nonobviousness against a patent for an eyeglass hanger tag, used for displaying non-prescription glasses on a retail rack.¹³² The invention included a rigid plastic card with a hole, as illustrated below.¹³³

121. See *Ryko Mfg. Co. v. Nu-Star, Inc.*, 950 F.2d 714, 718 (Fed. Cir. 1991).

122. See Joseph P. Meara, Note, *Just Who Is the Person Having Ordinary Skill in the Art? Patent Law's Mysterious Personage*, 77 WASH. L. REV. 267, 293 (2002).

123. 774 F.2d 448, 454 (Fed. Cir. 1985).

124. 229 F.3d 1120, 1123 (Fed. Cir. 2000).

125. *Id.*

126. *Id.* at 1131; see also *Sandt Techn., Ltd. v. Resco Metal & Plastics Corp.*, 264 F.3d 1344 (Fed. Cir. 2001).

127. *In re Huang*, 100 F.3d 135, 139-40 (Fed. Cir. 1996).

128. *Id.* at 136.

129. *Id.* at 137.

130. *Id.* at 139.

131. 174 F.3d 1308, 1325-26 (Fed. Cir. 1999).

132. *Id.* at 1314, 1323.

133. U.S. Patent No. 4,976,532 fig. 4 (filed Dec. 1, 1988).

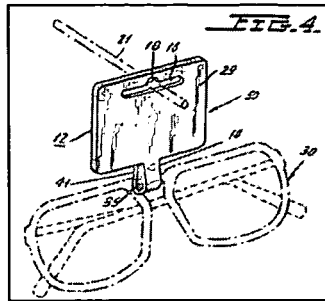

The prior art included the Seaver patent, which included a tag and strap attached by using a rivet for attaching price or manufacturer information, as follows:¹³⁴

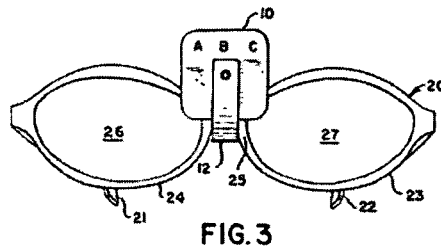

The *Al-Site* defendant argued obviousness because one of ordinary skill would have had only to place a hole on the Seaver security tag to hang them on a support bracket.¹³⁵ Rejecting this argument, the court observed that Seaver lacked elements, including the display member, the bracket and the hole in the tag.¹³⁶ The *Al-Site* court did not mention that the patents in suit were intended for use “at pharmacies and other retail outlets,”¹³⁷ where bracket displays are commonly used for many types products. Further, *Al-Site* did not discuss that another reference asserted by the defendant described an eyeglass display card with “an aperture . . . located so as to be centered above the eyeglass frame in the stored position of the temple bar attached thereto, whereby the display card . . . can be conveniently suspended from a hook or the like.”¹³⁸ Cases such as *Al-Site* demonstrate that, under some decisions prior to the Supreme Court’s *KSR* decision, the inferences that those of skill in the art could exercise were extremely limited.

134. *Al-Site*, 174 F.3d at 1323. See U.S. Patent No. 3,738,034 fig. 3 (Sept. 15, 1971) (‘034 patent).

135. *Al-Site*, 174 F.3d at 1324.

136. *Id.*

137. ‘034 patent, *supra* note 134, at col. 1, ln. 14.

138. U.S. Patent No. 3,291,300 (filed Jan. 26, 1966).

H. *The Federal Circuit's Teaching-Suggestion-Motivation Test*

In part, the *Al-Site* case was based on the Federal Circuit's teaching-suggestion-motivation test, which became known as the "TSM test." This inquiry "asks not merely what the references disclose, but whether a person of ordinary skill in the art, possessed with the understandings and knowledge reflected in the prior art, and motivated by the general problem facing the inventor, would have been led to make the combination recited in the claims."¹³⁹ The TSM test, which derived from the predecessor Court of Customs and Patent Appeals, was intended to ensure proper application of the rule that a claim's nonobviousness must be assessed as of the time of the invention under examination.¹⁴⁰ By requiring the state of the art at the time of invention to have sufficient information to teach, suggest or motivate one of ordinary skill to re-create the invention, the TSM test was intended to eliminate "hindsight bias."¹⁴¹ Hindsight bias was described by the Supreme Court in 1911:

Knowledge after the event is always easy, and problems once solved present no difficulties, indeed, may be represented as never having had any, and expert witnesses may be brought forward to show that the new thing which seemed to have eluded the search of the world was always ready at hand and easy to be seen by a merely skillful attention.¹⁴²

As applied in some cases, the TSM test required an articulated basis in the prior art that would have led one in the art to make the invention.¹⁴³ In other words, some opinions applied the TSM test in a manner that, unless a

139. See *In re Kahn*, 441 F.3d 977, 988 (Fed. Cir. 2006) ("[T]here must be some articulated reasoning with some rational underpinning to support the legal conclusion of obviousness.").

140. See, e.g., *In re Bergel*, 292 F.2d 955, 956-57 (1961). Upon its formation, the Federal Circuit adopted all prior holdings of the Court of Claims and the Court of Customs and Patent Appeals as the precedent "most applicable to the areas of law within the substantive jurisdiction" of the court. *South Corp. v. United States*, 690 F.2d 1368, 1370 (Fed. Cir. 1982); see also 35 U.S.C. § 103(a) (2006) (stating that obviousness must be assessed as of "the time the invention was made").

141. See generally Gregory N. Mandel, *Patently Non-Obvious: Empirical Demonstration that the Hindsight Bias Renders Patent Decisions Irrational*, 67 OHIO ST. L.J. 1391, 1393 (2006) ("The core requirement for obtaining a patent is that the invention was not obvious at the time it was invented. . . . A proper non-obvious decision must not take into account the ex post fact that the invention was actually achieved."); *Orthopedic Equip. Co., Inc. v. United States*, 702 F.2d 1005, 1012 (Fed. Cir. 1983).

142. *Diamond Rubber Co. of N.Y. v. Consol. Rubber Tire Co.*, 220 U.S. 428, 435 (1911).

143. *In re Rouffet*, 149 F.3d 1350, 1359 (Fed. Cir. 1998); see also *Pfizer, Inc. v. Apotex, Inc.*, 480 F.3d 1348, 1361 (Fed. Cir. 2007).

fact-finder could *identify* a textual (or graphic) basis for a teaching, suggestion or motivation for the PHOSITA to re-create an invention, the claim would be found nonobvious.¹⁴⁴

Although hindsight bias was thought to be particularly problematic for inventions made of combinations of preexisting elements,¹⁴⁵ as a practical matter, “. . . the TSM test was applied where nonobviousness challenges were based either on multiple references¹⁴⁶ or a single reference.”¹⁴⁷ In addition, under pre-KSR law, a person of ordinary skill must have acted with a reasonable expectation of success; solutions that were merely obvious to try were not sufficient to invalidate a patent.¹⁴⁸

The TSM test was criticized as, in effect, artificially limiting the reach of the nonobviousness doctrine.¹⁴⁹ As Professor Duffy explained, “The test evolved into such rigid a rule that the Patent and Trademark Office believed it could not reject a patent application unless it was able to ‘connect the dots’ from the prior art ‘very, very clearly.’”¹⁵⁰ Rather than examining a claim to assess the degree of an invention’s advance to an art, cases focused on the sufficiency of evidence of the teaching, suggestion or motivation to combine.¹⁵¹ As a result, a court’s conclusions about the person of ordinary skill

144. Some of these decisions include *In re Zurko*, 258 F.3d 1379 (Fed. Cir. 2001), *In re Kotzab*, 217 F.3d 1365 (Fed. Cir. 2000), and *In re Dembiczak*, 175 F.3d 994 (Fed. Cir. 1999).

145. See *In re Rouffet*, 149 F.3d at 1355 (“When a rejection depends on a combination of prior art references, there must be some teaching, suggestion, or motivation to combine the references.”).

146. See *Akamai Techns., Inc. v. Cable & Wireless Internet Servs., Inc.*, 344 F.3d 1186, 1196 (Fed. Cir. 2003).

147. See *SIBIA Neurosciences, Inc. v. Cadus Pharm. Corp.*, 225 F.3d 1349, 1356 (Fed. Cir. 2000) (“[I]n appropriate circumstances, a single prior art reference can render a claim obvious. However, there must be a showing of a suggestion or motivation to modify the teachings of that reference to the claimed invention in order to support the obviousness conclusion.” (citations omitted)); *B.F. Goodrich Co. v. Aircraft Braking Sys. Corp.*, 72 F.3d 1577, 1582-83 (Fed. Cir. 1996).

148. See *Ecolochem, Inc. v. S. Cal. Edison Co.*, 227 F.3d 1361, 1372 (Fed. Cir. 2000).

149. See *DyStar Textilfarben GmbH & Co. Deutschland KG v. C.H. Patrick Co.*, 464 F.3d 1356, 1365 (Fed. Cir. 2006) (describing and citing criticisms).

150. Duffy, *supra* note 39, at 63 (quoting a statement of the Patent and Trademark Office’s Deputy Commissioner for Examination Policy, as found in FTC REPORT, *supra* note 7, ch. 4, at 11).

151. See Christopher A. Cotropia, *Patent Law Viewed Through an Evidentiary Lens: The “Suggestion Test” as a Rule of Evidence*, 2006 BYU L. REV. 1517, 1536-42 (collecting pre-KSR cases where “a narrow suggestion test” is apparently used, suggesting that an interpretation of such cases may be that the Federal Circuit is reviewing the record for evidentiary sufficiency).

“seem[ed] to do little work in guiding its own review of the ultimate conclusion as to patentability.”¹⁵²

Further, the Federal Circuit developed a rule that prohibited rejections based on a PHOSITA’s use of “common knowledge and common sense.”¹⁵³ Some justifications for the rule were offered. For example, the Federal Circuit, in *In re Lee*, observed that terminology such as “common sense,” when used by a government agency, may hide fact-finding under “the haze of so-called expertise” and thereby “acquire insulation from accountability.”¹⁵⁴ Despite these worthy purposes, the effect of the rules, in combination with the TSM test, lowered the standard for nonobviousness. In 2004, Professor Eisenberg wrote that the Federal Circuit had “extend[ed] Judge Rich’s presumption that PHOSITA is a conventional thinker who is not inclined to innovate by further presuming that PHOSITA lacks the capacity to synthesize the teachings of others on his own.”¹⁵⁵

IV. KSR: EXPANDING THE PHOSITA’S CAPABILITIES

The term “ordinary creativity,” first used in patent jurisprudence in *KSR*, appeared in an amicus brief filed by certain law professors in support of the petitioner.¹⁵⁶ This brief relied, in turn, on the Federal Trade Commission’s 2003 report, *To Promote Innovation: The Proper Balance of Competition and Patent Law and Policy*, which had been prepared by the agency after joint hearings held with the Department of Justice.¹⁵⁷ The FTC Report stated that a person of ordinary skill is capable of “creativity and insight”.¹⁵⁸ “Inventive processes typically involve judgment, experience, and common sense capable of connecting some dots. The suggestion test, rigidly applied, assumes away a PHOSITA’s typical levels of creativity and insight and supports findings of nonobviousness even when only a modicum of additional insight is

152. Rebecca S. Eisenberg, *Obvious to Whom? Evaluating Inventions from the Perspective of PHOSITA*, 19 BERKELEY TECH. L.J. 885, 890 (2004).

153. *In re Lee*, 277 F.3d 1338, 1344-45 (Fed. Cir. 2002); see also *In re Zurko*, 258 F.3d 1379, 1385-86 (Fed. Cir. 2001) (reversing a finding of nonobviousness by the Board of Patent Appeals and Interferences that relied on the PHOSITA’s exercise of common sense as “lack[ing] substantial evidence support”).

154. *In re Lee*, 277 F.3d at 1345.

155. Eisenberg, *supra* note 152, at 890-91, 894 (“[T]he Federal Circuit has generally focused on the prior art references themselves, consulting the perspective of PHOSITA only to determine what those references would reveal and suggest to a trained reader rather than to illuminate whether the invention would have seemed obvious to such a person.”).

156. Brief for Intellectual Property Law Professors as Amici Curiae Supporting Petitioner at 14, *KSR Int’l Co. v. Teleflex Inc.*, 550 U.S. 398 (2006) (No. 04-1350).

157. See FTC REPORT, *supra* note 7.

158. *Id.* at ch. 4, at 14.

needed.”¹⁵⁹ The FTC’s report, which referenced “a PHOSITA’s typical level[] of creativity and insight” and “problem-solving skills,” did not cite legal authority.¹⁶⁰ Rather, the report relied on testimony from attorneys who had worked in-house at corporations and described, for example, “company’s engineers, who ‘every day’ independently invent things that have been deemed nonobvious.”¹⁶¹ In short, the application of the nonobviousness doctrine was criticized as allowing patents for trivial advances.

In part, *KSR* was the Supreme Court’s response to the perceived rigidity of the Federal Circuit’s application of the TSM test.¹⁶² *KSR* expressed concern that “[g]ranting patent protection to advances that would occur in the ordinary course without real innovation retards progress and may, in the case of patents combining previously known elements, deprive prior inventions of their value or utility.”¹⁶³ As one piece of the overall assessment of nonobviousness, *KSR* significantly modified the person of ordinary skill construct in language that appeared to infuse a PHOSITA with qualities that more closely matched a human counterpart.

In particular, the *KSR* Court reasoned that one of ordinary skill was likely to look elsewhere in the field for analogous solutions and not simply, as the Federal Circuit had found in the decision below, to the problem to be solved by the inventor of the patent at issue.¹⁶⁴ As the *KSR* Court stated, “[F]amiliar items may have obvious uses beyond their primary purposes, and in many cases a person of ordinary skill will be able to fit the teachings of multiple patents together like pieces of a puzzle.”¹⁶⁵ Rejecting the Federal Circuit’s requirement for a reasonable expectation of success, the Court explained that a PHOSITA was likely to pursue known options within reach where there was “a design need or market pressure to solve a problem and there are a finite number of identified, predictable solutions.”¹⁶⁶ The *KSR* opinion noted that a person of ordinary skill is a person capable of learning from the prior

159. *Id.*

160. *See id.* at ch. 4, at 14, 44.

161. *Id.* at Executive Summary, at 12 n.45 (testimony of Robert Barr, who was then Worldwide Patent Counsel of network equipment company Cisco Systems, Inc.). *See also id.* at ch. 4, at 12 n.70 (testimony of Cecil Quillen, formerly of Kodak). In addition, the report observed the economic harm that can result where trivial patents are deemed nonobvious. *Id.* at Executive Summary, at 12.

162. *KSR Int’l. Co. v. Teleflex Inc.*, 550 U.S. 398, 419 (2007) (“The obviousness analysis cannot be confined by a formalistic conception of the words teaching, suggestion, and motivation, or by overemphasis on the importance of published articles and the explicit content of issued patents.”).

163. *Id.*

164. *Id.* at 421.

165. *Id.* at 420.

166. *Id.* at 421.

art and exercising common sense, that is, “a person of ordinary creativity, not an automaton.”¹⁶⁷

KSR allows the hypothetical person of ordinary skill to approach the capabilities of real world engineers and scientists. Yet few, if any, prior patent cases shed any light on how such individuals accomplish their tasks. What should decision makers consider as a product of mental acts like “common sense” and “ordinary creativity,” as distinguished from inventive mental acts? Though clearly the Court did not intend to re-awaken *Cuno*’s “flash of creative genius” standard,¹⁶⁸ *KSR* leaves open vital questions about exactly what the Court *did* mean to do.

At the time *KSR* was decided, the prior two centuries of patent law had swung from defining invention as an exercise of an indefinable quality, or even a flash of genius, to the Federal Circuit’s precise examination of the evidentiary record under the TSM test. What is left in *KSR*’s wake is far less certain. In the course of infusing the person of ordinary skill with these qualities, *KSR* redirected nonobviousness in a direction that is intended to serve scientific interests by resting on predictability as the predominant focus.¹⁶⁹ Additionally, the *KSR* Court observed that information beyond that in prior art should be considered in an overall, flexible assessment, including design trends within the relevant industry.¹⁷⁰ Further, according to the *KSR* opinion, “a court can take account of ‘the inferences and creative steps’ that a person of ordinary skill in the art would employ.”¹⁷¹

One might anticipate that fewer advances will be patentable under *KSR* than under prior law. A person of ordinary skill with *some* creative capability, working with a broader array of information and sensitive to the design needs of the market, will have the capability to re-create more inventions than one who does not. What is far less clear is how to tell which inventions fall on the patentable side of the nonobviousness line and which end up on the other.

Since *KSR* was decided, one sentence has become singularly significant: “When there is a design need or market pressure to solve a problem and there are a finite number of identified, predictable solutions, a person of ordinary skill has good reason to pursue the known options within his or her technical grasp.”¹⁷² The PTO has issued an interpretive memorandum that relies on

167. *Id.* at 419-22.

168. *Cuno Engineering Corp. v. Automatic Devices Corp.*, 314 U.S. 84, 91 (1941). *KSR* expressly reaffirmed the framework set forth in *Graham v. John Deere Co.*, 383 U.S. 1 (1966), which held that the 1952 enactment of 35 U.S.C. § 103 eliminated *Cuno*’s “flash of creative genius” standard. *Id.* at 406-07.

169. *KSR Int’l Co.*, 550 U.S. at 415-22.

170. *Id.* at 419 (“[I]t often may be the case that market demand, rather than scientific literature, will drive design trends.”).

171. *Id.* at 418.

172. *Id.* at 421.

this statement to assist examiners in implementing *KSR*.¹⁷³ Five of the seven considerations from the PTO guidelines are driven by the predictability of the result.¹⁷⁴ Yet the term “predictability” presents the same definitional problems as “creativity” and “common sense.” The notion that something is predictable is another way of saying that no creativity is required to resolve the problem – that is, that one merely needs to confirm or make a narrow inference to achieve a result. By itself, the word suffers from indeterminacy as a legal standard.

A. *Post-KSR: Scientific Creativity in the Courts*

The Federal Circuit’s post-*KSR* decisions have relied on predictability as the dispositive breakpoint of the nonobviousness inquiry. Likewise, the court has relied on *KSR*’s admonition that patent claims are nonobvious when the combination consists of combining elements in the prior art “together like pieces of a puzzle.”¹⁷⁵ In several cases finding a patent obvious, the technology at issue was straightforward and mature.

For example, in *Rothman v. Target Corp.*, the Federal Circuit held that claims directed to an item of clothing with a built-in nursing bra were obvious.¹⁷⁶ Finding that the creation of garments was part of a highly predictable field, the court held that one of ordinary skill would have been capable of combining a prior art tank-top shirt with a prior art nursing bra and that the result functioned as expected.¹⁷⁷ Affirming a jury finding of obviousness, the court in *Rothman* noted that the market at the time of invention called for the development of active wear designs.¹⁷⁸

Similarly, *Ball Aerosol and Specialty Container, Inc. v. Limited Brands, Inc.* involved claims directed to a candleholder with a removable cover with protrusions that prevented scorching on table surfaces when the cover was flipped over.¹⁷⁹ Reversing the district court’s finding of validity, the *Ball Aerosol* court directed that summary judgment of invalidity be entered.¹⁸⁰ The Federal Circuit explained that the lower court had “erred by failing to take account of the ‘inferences and creative steps,’ or even routine steps, that an inventor would employ and by failing to find a motivation to combine related pieces from the prior art.”¹⁸¹

173. Examination Guidelines for Determining Obviousness Under 35 U.S.C. 103 in View of the Supreme Court Decision in *KSR International Co. v. Teleflex Inc.*, 72 Fed. Reg. 57526 (Oct. 10, 2007).

174. *Id.* at 57529.

175. *KSR Int’l Co.*, 550 U.S. at 420.

176. 556 F.3d 1310, 1320 (Fed. Cir. 2009).

177. *Id.* at 1319-20.

178. *Id.* at 1320.

179. 555 F.3d 984, 986 (Fed. Cir. 2009).

180. *Id.* at 994.

181. *Id.* at 993.

In *Leapfrog Enterprises v. Fisher-Price, Inc.*, the Federal Circuit considered nonobviousness for claims that described a device for an interactive electronic reading toy.¹⁸² The patent at issue described a device for producing sound from a user's selection of letters using a "reader" that the user passed over words printed on a page. One piece of prior art described a device whereby users pushed a mechanical puzzle piece that activated a motor that turned a phonograph to play a portion of a record that corresponded to the selected sound, typically a single letter.¹⁸³ A second piece of prior art, an electronic reader called the SSR, read custom-made books using an electronic processor, memory and a speaker that read aloud syllabic portions of words printed in the book when pressed by the user.¹⁸⁴ Neither the reader nor the method of incorporating the reader was mentioned in the phonograph or SSR pieces of prior art.¹⁸⁵ Reviewing the district court's findings de novo, the Federal Circuit found the invention obvious.¹⁸⁶ Noting that existing technical conventions within the relevant domain were sufficient to accomplish the invention, the court explained, "The combination is thus the adaptation of an old idea or invention (Bevan) using newer technology that is commonly available and understood in the art (the SSR)."¹⁸⁷

Rothman, Ball Aerosol and *Leapfrog* apply KSR; all appear correct in their results. Further, all apply to comparatively simple, predictable technology. Unlike *Al-Site*, these cases infuse the person of ordinary skill with the mental capability to combine elements without the need for express written direction.¹⁸⁸ Yet perhaps because the PHOSITA is relying on tacit information to accomplish the invention in these cases, the Federal Circuit's reasoning appears to rest on rather opaque conclusions about the inventive process. As in *Winslow*, these opinions provide little insight or guidance that can be applied to assess other types of inventions. No opinion fully and meaningfully articulates a hypothetical reconstruction of an invention that provides a framework for assessing future inventions.

B. Post-KSR Nonobviousness: Complex Technologies

The 2007 opinion in *Pfizer, Inc. v. Apotex, Inc.*¹⁸⁹ presents an interesting opportunity to examine a single case that spans both pre-KSR and its after-

182. *Leapfrog Enters. v. Fisher-Price, Inc.*, 485 F.3d 1157, 1158, 1160-63 (Fed. Cir. 2007).

183. *Id.* at 1161.

184. *Id.* at 1162.

185. *Id.*

186. *Id.*

187. *Id.*

188. See generally Dan L. Burk, *The Role of Patent Law in Knowledge Codification*, 23 BERKELEY TECH. L.J. 1009 (2008) (discussing KSR's consideration of tacit information in assessing nonobviousness).

189. 480 F.3d 1348 (Fed. Cir. 2007).

math. There, the Federal Circuit examined nonobviousness allegations for claims directed to a treatment for angina and hypertension.¹⁹⁰ Pfizer scientists had previously developed a compound, amlodipine, to treat the diseases, but it lacked stability.¹⁹¹ The inventor of the patent in suit, Pfizer's Dr. Wells, derived a besylate salt to combine with amlodipine to solve the problem, and this combination was claimed in the patent in suit.¹⁹²

The district court found the claim nonobvious, noting that the salt delivered "unexpectedly superior" results and that the compound had been rarely used in other pharmaceutical contexts prior to the time of invention.¹⁹³ On appeal, just days before *KSR* was decided, a Federal Circuit panel reversed, finding the claim obvious as a matter of law.¹⁹⁴ Specifically, the court reasoned that the PHOSITA would consult various sources to locate FDA-approved salts and then "was capable of further narrowing that list . . . to a much smaller group, including benzene sulphonate, with a reasonable expectation of success."¹⁹⁵ The appellate panel accepted the district court's finding that at the time of invention "there was no reliable way to predict the influence of particular salt species on the active part of the compound."¹⁹⁶ Nonetheless, the court held that one of ordinary skill would have been able to reproduce the invention using routine experimentation.¹⁹⁷

After *KSR* was decided, three judges dissented from the Federal Circuit's refusal to rehear the case en banc.¹⁹⁸ All three noted that the general state of the relevant art was unpredictable.¹⁹⁹ As Judge Rader observed, the formation of new salts for pharmaceuticals is "entirely unpredictable," and this specific invention was unexpected when it was derived.²⁰⁰ These dissenting opinions recognized that the panel's decision was contrary to the needs of the industry, consistent with Justice Rader's statement that the panel "decision calls into question countless pharmaceutical patents, which in turn could

190. *Id.* at 1351.

191. *Id.* at 1353-54.

192. *Id.* at 1354.

193. *Id.* at 1356-57.

194. *Id.* at 1359.

195. *Id.* at 1366.

196. *Id.* at 1364.

197. *Id.* at 1364-65. Appearing to overstep the rule that the inventor's inventive process should not be considered, the panel noted that, during the process of invention, "Dr. Wells [had] compiled a list of seven alternative anions – including the besylate – each of which he expected would form an amlodipine acid addition salt." *Id.* at 1364.

198. *Pfizer, Inc. v. Apotex, Inc.*, 488 F.3d 1377, 1378-79 (Fed. Cir. 2007) (order denying en banc rehearing) (Newman, Lourie & Rader, J.J., dissenting).

199. *Id.* at 1379, 1383-84 (Newman, Lourie & Rader, J.J., dissenting).

200. *Id.* at 1384 (Rader, J., dissenting).

have a profoundly negative effect on investments into the design and development of new life-saving pharmaceuticals.”²⁰¹

The disagreement between the panel and the dissents from the denial for en banc rehearing demonstrates a lack of coherent thinking about the word “predictable” when assessing nonobviousness. The panel focused on predictability of the inventive *process* – using the *Winslow* reconstruction – by the person of ordinary skill.²⁰² Finding a limited number of options available, the panel concluded that a PHOSITA would explore a number of well-defined options and arrive at a non-patentable combination.²⁰³ The dissenting opinions focused on the predictability of the *technological field* and the economic consequences of denying this patent on the industry.²⁰⁴

*Pharmastem Therapeutics, Inc. v. Viacell, Inc.*²⁰⁵ is a post-*KSR* decision that stands for the proposition that new pathways may be found obvious where signs point in a positive direction and the results are affirmed by routine experimentation. The *Pharmastem* court considered nonobviousness asserted against claims directed to treating patients with progenitor and stem cells derived from umbilical cord blood.²⁰⁶ Certain sources in the prior art suggested that cord blood could be used for that purpose, although that finding had not been confirmed at the time of invention.²⁰⁷ The patentee’s expert testified that a critical piece of information – that is, whether stem cells were actually present in cord blood – was not known until tested by the inventors conducting experiments using mice.²⁰⁸ The expert testified, “[I]t had to take a leap of thinking that cord blood was different.”²⁰⁹

Nonetheless, the *Pharmastem* majority found the invention obvious as a matter of law.²¹⁰ Focusing primarily on a hypothetical reconstruction, *Pharmastem* noted that routine research methods had been used to confirm suggestions in the prior art that cord blood could be used, noting, “Scientific confirmation of what was already believed to be true may be a valuable contribution, but it does not give rise to a patentable invention.”²¹¹ Nonetheless, *Pharmastem* acknowledged that the inventor’s “work may have significantly advanced the state of science of hematopoietic transplantations by eliminating any doubt as to the presence of stem cells in cord blood.”²¹² In essence, *Pharmastem* viewed re-creation of the claim as the work of an ordinarily

201. *Id.* 1380, 1383-84 (Newman, Lourie & Rader, J.J., dissenting).

202. *Pfizer, Inc.*, 480 F.3d at 1369. *See supra* note 110 and accompanying text.

203. *Pfizer, Inc.*, 480 F.3d at 1362.

204. *See, e.g., Pfizer, Inc.*, 488 F.3d at 1379 (Newman, J., dissenting).

205. 491 F.3d 1342 (Fed. Cir. 2007).

206. *Id.* at 1347.

207. *Id.* at 1360.

208. *Id.* at 1361.

209. *Id.*

210. *Id.* at 1367.

211. *Id.* at 1363-64.

212. *Id.* at 1363.

skilled, ordinarily creative PHOSITA using routine testing methods to merely confirm suggestions already existing in the art. Underlying this result is the majority's assumption that the result was predictable because the PHOSITA would have had a reasonable expectation of success when undertaking these tests.²¹³

Judge Newman dissented from the panel opinion, focusing on predictability within the field more broadly.²¹⁴ Her dissent noted that the record included skepticism in the art, the failure by others who had attempted this work and recognition that the invention would have considerable value if ever achieved.²¹⁵ Newman stated,

The undisputed evidence at trial was that these long-sought life-saving inventions were achieved amid general scientific skepticism, despite the extensive research that was being conducted by many scientists in this field, as set forth in the patents in suit. The discoveries of these inventors were met with universal acclaim and widespread utilization, including the founding of many commercial enterprises, all of which are reported to have licensed the patents except for these defendants. Unimpressed by these considerations, my colleagues on this panel now reconstruct these inventions by selection and inference, with perfect hindsight of the discoveries.²¹⁶

In *Pharmastem*, the majority focused on the hypothetical recreation using particularly identified references. Judge Newman's dissent considered the state of uncertainty in the research field as a whole to reach an opposite conclusion. It is evident that "creativity" and "predictability" are subject to different views amongst members of the patent judiciary.

Other recent cases underscore conceptual differences among Federal Circuit panels applying *KSR*, including divergent judicial understandings of predictability. In *Ortho-McNeil Pharmaceutical, Inc. v. Mylan Laboratories, Inc.*, the Federal Circuit focused on the inventor's process developing a chemical to treat epilepsy.²¹⁷ *Ortho-McNeil* recognized that *KSR* directed that "a design need or market pressure" may prompt exploration of a limited amount "of identified, predictable solutions . . . within [one's] technical grasp."²¹⁸ Nonetheless, the *Ortho-McNeil* decision found the invention non-obvious, noting that the inventor had unexpectedly discovered the claimed compound while searching for a diabetes treatment and that a PHOSITA

213. *See id.* at 1360.

214. *Id.* at 1367 (Newman, J., dissenting).

215. *Id.*

216. *Id.* at 1368 (citation omitted) (Newman, J., dissenting).

217. 520 F.3d 1358, 1360 (Fed. Cir. 2008).

218. *Id.* at 1364.

could not have developed this treatment based on a straightforward application of the epilepsy prior art.²¹⁹

By contrast, in *Abbott Laboratories v. Sandoz, Inc.*, the court focused primarily on predictability *within the field* when considering a claim for an extended release formulation for the antibiotic clarithromycin.²²⁰ *Abbott* drew a distinction between an “investigator’s educated application of what is known [and] intelligent exploration of what is not known” and found that the field created “difficulties in predicting the behavior of any composition in any specific biological system.”²²¹ In the end, the Federal Circuit affirmed the trial court’s finding that the claims were likely nonobvious.²²² Similarly, in *Sanofi-Synthelabo v. Apotex*, the court affirmed a finding of nonobviousness for a chemical compound for the pharmaceutical Plavix®, based on findings that the result was unpredictable and the testing methodology was undefined.²²³

An entirely different approach is seen in *Board of Trustees of the Leland Stanford Junior University v. Roche Molecular Systems, Inc.*, a district court decision examining claims directed to a method for using RNA to treat human immunodeficiency virus (HIV).²²⁴ The art suggested the use of HIV RNA as a promising possibility and provided methods to quantify the substance.²²⁵ Up to twenty different alternatives to HIV RNA were suggested, although the state of the art was discordant and uncertain at the time of invention.²²⁶ The *Stanford* court found the invention obvious, noting that the inventor’s choice to study HIV RNA was merely “a preliminary choice on the route to developing methods to evaluate therapy efficacy.”²²⁷ The *Stanford* court declined to credit the scientist for the selection of HIV RNA against the weight of then-current literature.²²⁸ Rather, *Stanford* focused on the researcher’s incentives,²²⁹ particularly that there was “no evidence that scientists had scores of other possibilities for research.”²³⁰ The *Stanford* court held the claims obvious despite the fact that the claimed invention appeared to

219. *Id.* at 1364 (“[T]he ordinary artisan in this field would have had to (at the time of invention without any clue of potential utility of topiramate) stop at that intermediate and test it for properties far afield from the purpose for the development in the first place (epilepsy rather than diabetes).”).

220. 544 F.3d 1341, 1343 (Fed. Cir. 2008).

221. *Id.* at 1351-52.

222. *Id.* at 1353, 1371.

223. 550 F.3d 1075, 1077, 1090 (Fed. Cir. 2008).

224. 563 F. Supp. 2d 1016, 1021 (N.D. Cal. 2008), *rev’d on other grounds*, 583 F.3d 832 (Fed. Cir. 2009).

225. *Id.* at 1037.

226. *Id.* at 1027.

227. *Id.* at 1039, 1041-42.

228. *Id.* at 1043.

229. *Id.* at 1042.

230. *Id.*

represent an advance in the science, as evidenced by recognition by the National Institute of Health and the International AIDS Society.²³¹ *Stanford* viewed the addition of the measurement-as-correlation steps as “the obvious next step,” resulting in an invalid claim.²³²

This demonstrates that *KSR*, and judicial understandings of predictability, are not entirely cohesive. Despite the fact that these decisions all derive from the pharmaceutical industry, which would benefit from a consistent form of analysis, the ultimate patentability decision rests on uncertain footing.

V. TOWARD AN UNDERSTANDING OF SCIENTIFIC CREATIVITY

The question of how people solve problems has been studied for centuries outside the field of patent law.²³³ Certainly, any legal system should be wary of embracing definitions outside the law given that research performed in other fields does not have justice as a goal. Nonetheless, a review of these fields illuminates *possible* understandings of creativity, which the law may choose to accept or reject. This Section considers the most relevant aspects of interdisciplinary research considering the nature of human problem solving.

Patent law was placed in the U.S. Constitution “[t]o promote the Progress of Science and useful Arts.”²³⁴ Despite this consistent underlying purpose, invention is portrayed in a scattered fashion throughout patent case law. Perhaps the view that existed throughout most of the history of U.S. patent law is the U.S. Supreme Court’s former invention standard, which described protectable inventions as the product of “intuitive genius.”²³⁵ This perception was echoed as recently as 1996 by the Supreme Court in *Markman v. Westview Instruments, Inc.*, which observed that a purpose of the patent system was “the encouragement of the inventive genius of others.”²³⁶

The Federal Circuit has suggested that “[i]nventors, as a class, according to the concepts underlying the Constitution and the statutes that have created the patent system, possess something – call it what you will – which sets

231. *Id.* at 1035.

232. *Id.* at 1047.

233. See ORIGINS OF THE SCIENTIFIC MIND, *supra* note 9, at 16 (noting that the history of science has been documented since ancient Greece and Syria).

234. U.S. CONST. art I, § 8, cl. 8.

235. See, e.g., *C. & A. Potts & Co. v. Creager*, 155 U.S. 597, 608 (1895); *Cuno Eng’g Corp. v. Automatic Devices Corp.*, 314 U.S. 84, 91 (1941) (“[T]he new device, however useful it may be, must reveal the flash of creative genius not merely the skill of the calling. If it fails, it has not established its right to a private grant on the public domain.”).

236. 517 U.S. 370, 390 (1996) (quoting *Gen. Elec. Co. v. Wabash Appliance Corp.*, 304 U.S. 364, 369 (1938)).

them apart from the workers of ordinary skill.”²³⁷ Similarly, inventors have been described as “impelled to invest in creative effort” to obtain a patent.²³⁸ Other Federal Circuit opinions describe different qualities.²³⁹ For example, one opinion described invention as deriving from “insights, willingness to confront and overcome obstacles, and yes, even serendipity.”²⁴⁰ Another portrayed invention as “intelligent exploration of what is not known.”²⁴¹ These statements hint at effort, vision, knowledge and an element of chance but do not provide a cohesive structure that can readily guide a fact-finder’s decision. At present, articulated standards and a cohesive judicial philosophy regarding *how* patentable inventions are made is not ascertainable. The phrases “ordinary creativity” and “ordinary skill” imply that inventors are operating somewhere above this level, but it is difficult to say exactly where the line is, or should be, drawn.

Pre-*KSR*, the Federal Circuit’s nonobviousness jurisprudence relied heavily on whether the teaching, suggestion or motivation test was met. One scholar argues that this test resulted in a rules-based formalism.²⁴² At that time, *KSR*’s ordinary creativity standard did not exist, leaving little doctrinal space to explore the types of inferences or creative steps that a person of ordinary skill might employ. Post-*KSR*, a method to divine the difference between “ordinary creativity” and “patentable creativity” has yet to emerge. Moreover, unlike tort law’s reasonable person, for which a jury can be entrusted to bring common experience to assess conduct, it is unclear what sources of information a jury will rely upon to guide the hypothetical re-creation of technological subject matter.

237. *Standard Oil Co. v. Am. Cyanamid Co.*, 774 F.2d 448, 454 (Fed. Cir. 1985). See also *McGinley v. Franklin Sports, Inc.*, 262 F.3d 1339, 1351 (Fed. Cir. 2001) (referring to “[t]he genius of invention”).

238. *Biotechnology Indus. Org. v. Dist. of Columbia*, 496 F.3d 1362, 1372 (Fed. Cir. 2007).

239. For example, another Federal Circuit opinion acknowledges that “[r]eal inventors, as a class, vary in their capacities from ignorant geniuses to Nobel laureates.” *Kimberly-Clark Corp. v. Johnson & Johnson*, 745 F.2d 1437, 1454 (Fed. Cir. 1984).

240. *Ortho-McNeil Pharm., Inc. v. Mylan Labs., Inc.*, 520 F.3d 1358, 1364 (Fed. Cir. 2008). See also *Cal. Research Corp. v. Ladd*, 356 F.2d 813, 817 (D.C. Cir. 1966) (“The law has room for luck, and serendipity is certainly consistent with patentability.”).

241. *Abbott Labs. v. Sandoz, Inc.*, 544 F.3d 1341, 1352 (Fed. Cir. 2008) (“The methodology of science and the advance of technology are founded on the investigator’s educated application of what is known, to intelligent exploration of what is not known.”).

242. See John R. Thomas, *A Review of Recent Decisions of the United States Court of Appeals for the Federal Circuit*, 52 AM. U. L. REV. 771, 792 (2003) (“[T]here can be little doubt that a showing of a motivation to combine cited references has become increasingly formalized and rule-like. In nonobviousness, as with other areas of patent jurisprudence, adjudicative rule formalism has recently been a powerful influence.”).

A. *How Scientists Think: The Psychology of Science*

Early notions of creativity, which hinged on the concept of the creator as a genius based on speculations of either mysticism or madness, have been largely abandoned as later disciplines emerged.²⁴³ Currently, various fields have considered creativity, including history, philosophy, sociology, information theory and psychology.²⁴⁴ This Section considers these approaches with particular focus on the psychology of science.

Such research accepts that creativity is a complex human activity.²⁴⁵ A formal psychology of science has been underway in various forms since at least 1950, when the then-president of the American Psychological Association (APA), J.P. Guilford, placed creativity at the centerpiece of his presidential address.²⁴⁶ As Guilford recognized, “One scientist or engineer discovers a new principle or develops a new process that revolutionizes an industry, while dozens of others merely do a passable job on the routine tasks assigned to them.”²⁴⁷ Attempting to understand this distinction, a field has emerged and generated decades of research geared toward understanding how breakthrough invention occurs. Indeed, psychology as a discipline most directly considers the nature of an individual’s problem-solving behavior that is, as is all human behavior, controlled by the human mind. Other areas of the law have benefitted from examining literature from other disciplines as potential sources of information that may shed light on appropriate formulations of doctrine.²⁴⁸ This examination does not suggest that the law should crystallize this research necessarily into doctrine. Rather, this Article proposes that this

243. See Robert S. Albert & Mark A. Runco, *A History of Research on Creativity*, in HANDBOOK OF CREATIVITY 16, 18 (Robert J. Sternberg ed., 1999).

244. See generally *id.*

245. See Mark A. Runco & Shawn Okuda Sakamoto, *Experimental Studies of Creativity*, in HANDBOOK OF CREATIVITY 62, 62 (Robert J. Sternberg ed., 1999) (“Creativity is among the most complex of human behaviors.”).

246. J.P. Guilford, President, Am. Psychological Ass’n, *Creativity*, Address to the American Psychological Association (Sept. 5, 1950), in 5 AM. PSYCHOLOGIST 444 (1950), reprinted in J.P. Guilford, *Creativity Research: Past, Present and Future*, in FRONTIERS OF CREATIVITY RESEARCH 33 (Scott G. Isaksen ed., 1987) (subsequent citations will be to the reprinted version). See also Jonathan A. Plucker & Joseph S. Renzulli, *Psychometric Approaches to the Study of Human Creativity*, in HANDBOOK OF CREATIVITY 35, 36-37 (Robert J. Sternberg, ed. 1999) (stating that “J.P. Guilford’s 1950 APA Presidential Address[] . . . is traditionally considered the formal starting date of scientific creativity research” and describing efforts to study creativity prior to this time); ORIGINS OF THE SCIENTIFIC MIND, *supra* note 9, at 25-27.

247. Guilford, *supra* note 246, at 35.

248. See, e.g., Christopher Slobogin, *The Admissibility of Behavioral Science Information in Criminal Trials from Primitivism to Voice*, 5 PSYCHOL. PUB. POL’Y & L. 100 (1999); Jeremy A. Blumenthal, *Law and Social Science in the Twenty-First Century*, 12 S. CAL. INTERDISC. L.J. 1 (2002).

research can illuminate an area that has remained unexamined in patent law to assist in forming a foundation for a legal conception of creativity.

The literature throughout the science of psychology recognizes that ideas are not generated from thin air but rather come from building blocks of already existing ideas combined in new ways.²⁴⁹ As one psychologist wrote, “[N]o scientist, no matter how creative, can generate ideas from nothing.”²⁵⁰ Another wrote, “Anecdotal and historical accounts from real-world settings highlight the fact that new ideas, even highly creative ones, often develop as minor extensions of familiar concepts.”²⁵¹

Guilford’s writings theorize that people possess different types of intelligence and modes of thinking.²⁵² These processes include divergent thinking, which allows one to generate a number of logical alternatives to a problem for which there is no single answer.²⁵³ A useful contrast is the operation of the memory, which is the recollection of a fact that was previously known. Today, although Guilford’s theories on divergent thinking have endured, other theories have emerged that embellish, and in some instances displace, other aspects of his work.²⁵⁴

The term “creativity” has developed into a multi-dimensional concept that can be applied to results (such as a creative idea) or to the individuals who generate creative results (that is, creativity as an attribute of a person). “Creative” may describe a process – that is, the manner in which new ideas are created.²⁵⁵ In addition, a distinction may be drawn between predictable *processes* and the unpredictable *results* of that process. For example, one may apply a set of routine, well-established formulae to test a hypothesis that yields surprising – and therefore creative – results.

There is a remarkably high level of agreement among psychologists that creativity is defined as the generation of ideas that are both new and useful.²⁵⁶

249. ROBERT W. WEISBERG, *CREATIVITY: UNDERSTANDING INNOVATION IN PROBLEM SOLVING, SCIENCE, INVENTION, AND THE ARTS* 20 (2006) [hereinafter *UNDERSTANDING INNOVATION*] (noting that Watson and Crick’s discovery of the structure of DNA occurred “through the adoption and extension of already existing ideas that had been developed by someone else”).

250. DEAN KEITH SIMONTON, *CREATIVITY IN SCIENCE: CHANCE, LOGIC, GENIUS, AND ZEITGEIST* 171 (2004) [hereinafter *CREATIVITY IN SCIENCE*].

251. Thomas B. Ward, Steven M. Smith & Ronald A. Finke, *Creative Cognition*, in *HANDBOOK OF CREATIVITY* 189, 195 (Robert J. Sternberg ed., 1999).

252. Guilford, *supra* note 246, at 49.

253. *Id.*

254. See Robert J. Sternberg & Elena L. Grigorenko, *Guilford’s Structure of Intellect Model and Model of Creativity: Contributions and Limitations*, 13 *CREATIVITY RES. J.*, 309, 310 (2001) (observing that, although Guilford’s research on divergent thinking endures, “Guilford’s theory today is considered by many psychologists to be somewhat of a theory of the past”).

255. See *UNDERSTANDING INNOVATION*, *supra* note 249, at 1.

256. See, e.g., Richard E. Mayer, *Fifty Years of Creativity Research*, in *HANDBOOK OF CREATIVITY* 449, 449 (Robert J. Sternberg ed., 1999) [hereinafter *Fifty*].

To be considered useful, the idea must have value, or be likely to have value, within a relevant domain.²⁵⁷ For example, in the scientific realm, “[a] theory that is self-contradictory or that conflicts with the best established empirical findings may be original, but it cannot be considered creative.”²⁵⁸ Even if recognition is not evident when an idea is first introduced into the domain, the concept’s worth must be capable of having value, even if the idea does not currently have universal acceptance.

An analogy between this definition proffered by the psychology of science and patent law can be drawn. First, psychology’s emphasis on the newness of an idea may be equated to nonobviousness in patent law. Second, usefulness has an analogue in patent law’s utility requirement; however, for purposes of this paper, usefulness will not be examined so that the analysis can put substantial focus on nonobviousness.²⁵⁹ Nonetheless, it is important to recognize that the requirement that a creative solution be useful interposes a complication for the creative thinker. Specifically, the creative process must operate within certain constraints imposed by the relevant domain. For scientists and engineers to create useful ideas, established principles of physics, biology, engineering or the like will constrain the work, or these constraints must be deliberately tested. Likewise, creative authors must consider communicative principles and the perceptive ability of a reader, including

Years of Creativity Research] (among twenty submissions to the book, “the majority endorse the idea that creativity involves the creation of an *original and useful product*”); DEAN KEITH SIMONTON, *THE ORIGINS OF GENIUS: DARWINIAN PERSPECTIVES ON CREATIVITY* 5-6 (1999) [hereinafter *THE ORIGINS OF GENIUS*] (“an invention must not only be new, but it must also work”); Sarnoff A. Mednick, *The Associative Basis of the Creative Process*, 69 *PSYCHOL. REV.* 220, 221 (1962) (“defin[ing] the creative thinking process as the forming of associative elements into new combinations which either meet specified requirements or are in some way useful”); Robert J. Sternberg & Todd I. Lubart, *The Concept of Creativity: Prospects and Paradigms*, in *THE HANDBOOK OF CREATIVITY* 3, 3 (Robert J. Sternberg, ed. 1999) (defining “[c]reativity [a]s the ability to produce work that is both novel (i.e., original, unexpected) and appropriate (i.e., useful, adaptive, concerning task constraints)”). *But see* UNDERSTANDING INNOVATION, *supra* note 249, at 63-70 (observing that value is not a component of creativity). Weisberg states, “I see no reason to believe that psychological processes involved in producing a positively evaluated innovation are different in any way from a negatively evaluated one.” *Id.* at 68.

257. *See Fifty Years of Creativity Research*, *supra* note 256, at 449; *THE ORIGINS OF GENIUS*, *supra* note 256, at 5-6.

258. *THE ORIGINS OF GENIUS*, *supra* note 256, at 6.

259. An examination of the usefulness of inventions is outside the scope of this paper, which focuses on the ability to generate new ideas. However, as discussed *infra*, there is some relation between scientific constraints that contribute (or limit) the ability to create something new. All domains include some rules that must be considered in formulating new solutions. For example, those engaged in flight research must consider the forces of gravity in devising new flight methods.

rules of grammar that may be observed or consciously disregarded. Thus, to some degree, constraints limit creative choice.

Related to this principle, the nature of the problem to be solved is important when considering whether creativity is needed to derive a solution. Stated simply, some problems are more difficult to solve than others. Established scientific principles may lead one to a sole correct answer upon a relatively straightforward application.²⁶⁰ For example, if one asks the direction that an apple will take as it falls from a tree, the sole correct answer is “down.” Gravity’s pull is a constraint that leaves no room for choice. For these types of problems, answers can be formulated from already existing facts or accepted methods within the relevant domain, such as the principle of the earth’s gravitational pull within the field of physics.²⁶¹ To solve a problem, one may recall or consult relevant sources of information then apply the information to the problem at hand to obtain an answer.

On the other hand, questions that require a greater leap from existing methods or that leave multiple alternatives open are more likely to require creative thought to reach a resolution.²⁶² Answering questions such as how to eliminate malaria or design a fossil fuel alternative invokes open-ended thinking, which necessitates a broader search that may lead to any of several options.²⁶³ However, even well-formulated problems may be difficult to solve if those problems raise entirely new issues, do not rely on standard formulae or require the problem solver to create a new structure or method to reach a result. In all of these situations, existing knowledge cannot provide a ready answer. Generally, “[r]esearch on problem solving has demonstrated that

260. J.P. Guilford, *Can Creativity Be Developed?*, 11 ART EDUC. 3, 7 (1958).

261. Cf. Kevin Dunbar, *How Scientists Really Reason: Scientific Reasoning in Real-World Laboratories*, in THE NATURE OF INSIGHT 365, 382 (Robert J. Sternberg & Janet E. Davidson eds., 1995) (estimating that sixty percent of experiments in a biology lab “have technical problems that need to be resolved, and local analogical reasoning is one of the main methods that scientists use when they experience problems with the experiments”).

262. *Id.* See also Dean Keith Simonton, *Darwin as Straw Man: Dasgupta’s (2004) Evaluation of Creativity as a Darwinian Process*, 17 CREATIVITY RES. J. 299, 302 (2005) [hereinafter *Darwin as Straw Man*] (“[S]traightforward problem solving is less likely to produce ideas that would be considered creative.”). See generally Dunbar, *supra* note 261, at 382-84.

263. Distinctions between different types of problems have been articulated in alternative ways. For example, psychologist Richard Mayer discusses routine problems that one has already solved in the past or for which a ready-made solution exists, and non-routine problems, for which neither is true. See Richard E. Mayer, *The Search for Insight: Grappling with Gestalt Psychology’s Unanswered Questions*, in THE NATURE OF INSIGHT 3, 4 (Robert J. Sternberg & Janet E. Davidson eds., 1995) [hereinafter *Grappling with Gestalt Psychology’s Unanswered Questions*] (describing the origins of the theory).

tasks requiring more to be done to reach a solution yield more failures and slower solutions.”²⁶⁴

Further, these principles do not mean that an answer derived from the application of routine testing necessarily indicates a lack of creativity. For example, a scientist who obtains surprising results may do so by running a routine control test using standardized procedures to uncover a significant discovery. As a further example, a psychologist who studied biologists over a one-year period reported “that experimental results in which the control condition produces unusual results are very common and were the source of many discoveries in our studies.”²⁶⁵ Such breakthroughs can result even where the application of tried and true formulas ultimately leads to a solution or where a scientist is attempting to solve an entirely different problem.

A number of scholars who consider the nature of creativity do not view the operation of scientific and artistic creativity as fundamentally different. For example, debate about the nature of creativity is illustrated with reference to Picasso’s sketches that preceded his *Guernica* painting and the inventions of Thomas Edison.²⁶⁶ Certainly, scientists operate under different constraints than artists or authors.²⁶⁷ For the scientific and technological subject matter that forms a core of patentable subject matter, an appropriate level of knowledge and expertise in the relevant field is more often present than not.²⁶⁸ However, the psychology of science does not appear to uniformly support a notion that idea generation in either realm is completely different.

Sociologists Lee Fleming and Olav Sorenson have theorized that knowledge of the relevant, basic scientific principles performs an additional function in formulating advances.²⁶⁹ In constructing a model to demonstrate a relation between research of basic scientific principles and advances, Fleming and Sorenson rely on an analysis of patent citation to support the theory that

science acts like a map – providing inventors with a sense of the underlying technological landscape they search – thereby allowing them to avoid the difficulties inherent in trying to combine highly coupled components. [The] results demonstrate that scientific knowledge mitigates the negative effect that coupling typically has on the outcomes of invention.

264. Roger L. Dominowski & Pamela Dallob, *Insight and Problem Solving*, in THE NATURE OF INSIGHT 33, 37 (Robert J. Sternberg & Janet E. Davidson eds., 1995).

265. See Dunbar, *supra* note 261, at 389.

266. See *Darwin as Straw Man*, *supra* note 262, at 304-05; Robert W. Weisberg & Richard Hass, *We Are All Partly Right: Comment on Simonton*, 19 CREATIVITY RES. J. 345 (2007).

267. CREATIVITY IN SCIENCE, *supra* note 250, at 127-28.

268. *Id.*

269. See Lee Fleming & Olav Sorenson, *Science as a Map in Technological Search*, 25 STRATEGIC MGMT. J. 909, 911 (2004).

The Fleming-Sorensen theory provides a useful foundational analogy to describe interactions between established scientific principles and solutions described in patents. Nonetheless, the model operates at a level of generality that appears to stop short of describing the method by which scientists, and by analogy inventors, undertake creative endeavors. Ascertaining whether the exercise of creativity is ordinary or something more requires an examination of psychological theories that more directly examine this question.

B. *The Inventor as Genius*

The theme that invention derives from the inventor as genius is interwoven throughout patent case law. For example, the Supreme Court has articulated the underlying purpose of the patent system as including “the encouragement of the inventive genius of others.”²⁷⁰ The Court suggests that inventions are “bestowed by the genius and meditations and skill of individuals.”²⁷¹ *KSR* refers to the act of invention in sweeping terms, acknowledging that new works may be based on “extraordinary ideas, and sometimes even genius.”²⁷² Relying on a person of ordinary skill as determinative of nonobviousness implies a stratification of abilities – one who operates with “ordinary creativity” is contrasted with the inventor-genius who possesses a special ability to generate breakthroughs worthy of a patent.

In contrast, research outside the law more broadly supports a notion that creativity is a quality inherent in virtually everyone. As Guilford stated, “It is probably only a layman’s idea that the creative person is peculiarly gifted with a certain quality that ordinary people do not have. This conception can be dismissed by psychologists, very likely by common consent.”²⁷³ This principle resonates in more recent research, which concludes that “the capacity for creative thought is the rule rather than the exception.”²⁷⁴ Such research suggests that creativity exists in everyone and that any identified differences are “a matter of degree rather than kind.”²⁷⁵ One psychologist, Robert Weisberg, takes these conclusions one step further by positing that all problems are solved using a combination of existing information and the application of logical steps and that, therefore, any conception of scientific genius is a myth.²⁷⁶

270. *Markman v. Westview Instruments, Inc.*, 517 U.S. 370, 390 (1996) (quoting *General Elec. Co. v. Wabash Appliance Corp.*, 304 U.S. 364, 369 (1938)).

271. *eBay Inc. v. MercExchange, L.L.C.*, 547 U.S. 388, 392 (2006) (quoting *Fox Film Corp. v. Doyal*, 286 U.S. 123, 127-28 (1932)).

272. *KSR Int’l Co. v. Teleflex Inc.*, 550 U.S. 398, 427 (2007).

273. Guilford, *supra* note 246, at 36.

274. Ward et al., *supra* note 251, at 189. *See also id.* at 190 (“creative capacity is an essential property of normative human cognition”).

275. *CREATIVITY IN SCIENCE*, *supra* note 250, at 18.

276. *UNDERSTANDING INNOVATION*, *supra* note 249, at 146.

Although many psychologists do not believe that “genius” is a prerequisite to scientific advance, there is a body of work that examines whether the exercise of creativity “might require some special abilities or traits that set the great scientists apart from their lesser colleagues.”²⁷⁷ To uncover the factual underpinnings of this theory, studies have examined the qualities of creative scientists, in particular those who have either a highly prolific publication rate or high reputation level as reflected in awards and recognition. Early efforts proposed that creative scientists possess “flat associative hierarchies” – that is, such individuals have a broader conception of relevance, are able to draw from a broader range of resources when formulating solutions and can, thereby, generate more and sometimes better responses to a given question.²⁷⁸ Since this theory was first proposed, a myriad of other qualities of highly successful individuals have been examined.

One useful summary of this research is a 1998 meta-analysis performed by psychologist Gregory Feist, who performed a large-scale review of published literature that included, among other things, empirical work that ascertained personality differences between creative and non-creative scientists.²⁷⁹ Applying one set of criteria, Feist concluded that the research demonstrated that “creative scientists are more aesthetically oriented, ambitious, confident, deviant, dominant, expressive, flexible, intelligent, and open to new experiences than their less creative peers.”²⁸⁰ Applying a different set of criteria, Feist found that a more creative scientist “is tolerant and open-minded, self-accepting, outgoing, confident, ambitious, persistent and is a good judge of character.”²⁸¹ In short, the personality view of creativity suggests that those exercising higher levels of creativity think differently. Other research hypothesizes that high creativity may have a biologic basis.²⁸²

Training is viewed as important, and it has been observed that “[s]cientific creativity requires much more formal training than artistic crea-

277. CREATIVITY IN SCIENCE, *supra* note 250, at 7.

278. See Mednick, *supra* note 256, at 222, 223 & fig.1; Colin Martindale, *Biologic Bases of Creativity*, in HANDBOOK OF CREATIVITY 137 (Robert J. Sternberg ed., 1999).

279. Gregory J. Feist, *A Meta-Analysis of Personality in Scientific and Artistic Creativity*, 2 PERSONALITY & SOC. PSYCHOL. REV. 290 (1998) [hereinafter *Meta-Analysis of Personality*].

280. *Id.* at 296, 298 (applying the Five Factor Model of personality, a “relatively well agreed upon standardization of the basic dimensions of personality”). See also Mihaly Csikszentmihalyi, *Implications of a Systems Perspective for the Study of Creativity*, in HANDBOOK OF CREATIVITY 313, 329 (Robert J. Sternberg ed., 1999).

281. *Meta-Analysis of Personality*, *supra* note 279, at 298 (applying criteria from the California Psychological Inventory).

282. See Hans J. Eysenck, *Creativity and Personality: Suggestions for a Theory*, 4 PSYCHOL. INQUIRY 147 (1993); Martindale, *supra* note 278.

tivity.”²⁸³ Highly creative scientists appear to benefit from higher levels of formal education when compared to writers or visual artists.²⁸⁴ However, research on the impact of education on creative versus non-creative scientists is inconclusive.²⁸⁵ There is evidence that more distinguished scientists in the physical, biological and behavioral sciences have garnered more academic awards during the educational process.²⁸⁶ Further, the role of self-education through avid reading, hobbies, extra-curricular activities or other means of acquiring knowledge has been noted.²⁸⁷ Paradoxically, one summary reports that many highly creative scientists resist the process of formal education as interfering with an ability to think independently, concluding that “scientific talent must pull off a balancing act between mastering a domain and being mastered by a domain.”²⁸⁸

One might be tempted to conclude that those who score well on intelligence tests are likely to be successful scientists. Although there is considerable disagreement about the relationship between intelligence and creativity,²⁸⁹ some conclude that IQ tests are poor predictors of creative achievement.²⁹⁰

283. CREATIVITY IN SCIENCE, *supra* note 250, at 127. *See also id.* at 125-27 (observing that training is not always in the form of structured education and that some form of self-education and independent learning may provide the basis for later discoveries). UNDERSTANDING INNOVATION, *supra* note 249, at 212 (stating that there is a ten-year rule as the foundation for outstanding creative development). “[T]he results of many studies across varied domains indicate that world-class problem-solving performance is the result of a highly motivated individual employing domain-specific expertise that has been developed over years of immersion in the domain.” *Id.*

284. *See* CREATIVITY IN SCIENCE, *supra* note 250, at 125-27.

285. *Id.* at 128 (concluding that studies of the impact of education on creative versus noncreative scientists are somewhat ambiguous).

286. *Id.*

287. *Id.* at 129. Robert W. Weisberg, *Creativity and Knowledge: A Challenge to Theories*, in HANDBOOK OF CREATIVITY 226 (Robert J. Sternberg ed., 1999). Stephan Fuchs, *A Sociological Theory of Scientific Change*, 71 SOC. FORCES 933, 942 (1993) (“The knowledge and skills required to do innovative work are more tacit and personal, not rule-like and propositional.” (citations omitted)).

288. CREATIVITY IN SCIENCE, *supra* note 250, at 127. *See also id.* at 125-26 (quoting Albert Einstein, who stated that “[i]t is a very grave mistake to think that the enjoyment of seeing and searching can be promoted by means of coercion and a sense of duty”).

289. *See* Robert J. Sternberg & Linda A. O’Hara, *Creativity and Intelligence*, in HANDBOOK OF CREATIVITY 251 (Robert J. Sternberg ed., 1999) (collecting studies).

290. Kurt A. Heller, *Scientific Ability and Creativity*, 18 HIGH ABILITY STUD. 209, 211 (2007) (considering the results of a “meta-analysis of fifty international studies on the ability of personality characteristics to predict scientific and technical achievement,” which found that “[g]eneral intelligence and creativity tests had the lowest prognostic value”); *see also* THE ORIGINS OF GENIUS, *supra* note 256, at 78 (“[A] high level of intelligence cannot guarantee that a person will display an impressive degree of creativity. There are plenty of people with high-IQs, for example, who do not seem any more creative than individuals with average or even low IQ

Thus, intelligence as measured by such tests, by itself, is not sufficient to accomplish high levels of scientific creative success.²⁹¹ Some consider IQ tests too narrowly focused and propose that our concept of intelligence should be expanded to include other attributes, including creativity.²⁹² Thus, under this rubric, the question of whether there is a correlation between genius and creativity depends largely on how one defines the term “genius.”

These interdisciplinary views of individual creativity have not been imported into legal conceptions of invention. Prior to *KSR*, courts defined the person of ordinary skill solely with reference to education level, the relative complexity of the art and the existent knowledge base within the domain,²⁹³ the PHOSITA’s personality or mental capabilities are not discussed.²⁹⁴ Indeed, one can only ascertain the PHOSITA’s qualities by deconstructing judicial conclusions with respect to the nonobviousness question, and even then inconsistencies arise.²⁹⁵ Except for references to the concept of inventive genius as a laudable goal of the system, the cases are silent about an inventor’s individual attributes.²⁹⁶

There is possibly one exception to these generalities. Specifically, in 2006, the Federal Circuit’s *DyStar* opinion included a more layered explanation.²⁹⁷ In *DyStar*, where the technology at issue concerned a process for dyeing textiles, the court provided the following explanation:

scores.”); Robert J. Sternberg et al., *Testing Common Sense*, 50 AM. PSYCHOLOGIST 912, 913 (1995).

291. Eysenck, *supra* note 282, at 152 (“This proof that high IQ is a necessary condition for creative achievement is followed by proof that high IQ is not sufficient for high creative achievement.”); CREATIVITY IN SCIENCE, *supra* note 250, at 128.

292. See, e.g., Robert J. Sternberg, *Intelligence as Developing Expertise*, 24 CONTEMP. EDUC. PSYCHOL. 359, 363 (1999) (viewing intelligence as including “analytical, creative and practical” skills); HOWARD GARDNER, MULTIPLE INTELLIGENCES: THE THEORY IN PRACTICE (1993).

293. See *Daiichi Sankyo Co., Ltd. v. Apotex, Inc.*, 501 F.3d 1254, 1256 (Fed. Cir. 2007) (“Factors that may be considered in determining level of ordinary skill in the art include: (1) the educational level of the inventor; (2) type of problems encountered in the art; (3) prior art solutions to those problems; (4) rapidity with which innovations are made; (5) sophistication of the technology; and (6) educational level of active workers in the field.”).

294. See *Standard Oil Co. v. Am. Cyanamid Co.*, 774 F.2d 448, 454 (Fed. Cir. 1985) (“A person of ordinary skill in the art is also presumed to be one who thinks along the line of conventional wisdom in the art and is not one who undertakes to innovate, whether by patient, and often expensive, systematic research or by extraordinary insights, it makes no difference which.”).

295. See *supra* notes 189-223 and accompanying text.

296. See *supra* notes 23-37 and accompanying text.

297. *DyStar Textilfarben GmbH v. C.H. Patrick Co.*, 464 F.3d 1356, 1370 (Fed. Cir. 2006).

Persons of varying degrees of skill not only possess varying bases of knowledge, they also possess varying levels of imagination and ingenuity in the relevant field, particularly with respect to problem-solving abilities. If the level of skill is low, for example that of a mere dyer, as *DyStar* has suggested, then it may be rational to assume that such an artisan would not think to combine references absent explicit direction in a prior art reference. If, however, as we have held as a matter of law, the level of skill is that of a dyeing process designer, then one can assume comfortably that such an artisan will draw ideas from chemistry and systems engineering – without being told to do so.²⁹⁸

This passage from *DyStar* suggests that “imagination and ingenuity in the relevant field,” including “problem solving abilities,” rise linearly as the level of skill rises. It may be reasonable to assume that those with higher levels of skill, with a commensurately broader exposure to more information, will have more knowledge upon which to draw to make new combinations. However, it is the *DyStar* court’s view that it can be “comfortably assumed” that a lower educational level correlates with both a lower level of creativity and weaker problem-solving abilities. This view is not fully supported by creativity research. Instead, some research shows that abilities to combine disparate pieces of information, exercise imagination and solve difficult problems may derive in part from personality rather than exclusively from training, experience and education.

There may be policy justifications that support *DyStar*’s statement that high levels of skill correlate with imagination. In application, *DyStar*’s reasoning leads to obvious findings more frequently for those inventions requiring a higher level of skill in the art. However, inventions requiring a higher level of skill are precisely those that the patent system should foster, as those are the ones more likely to be fraught with unpredictability and risk and therefore more deserving of a patent. Notably, *DyStar*’s statement is unaccompanied by any explicit policy justification supporting this somewhat counterintuitive result.

This subfield considers creativity as an aspect of personality.²⁹⁹ Of all the theories, psychology’s study of genius accords with the rather scattered and vague language in the case law that invention derives from a mysterious quality possessed by a few. To the extent that patent law embraces this iconography, an understanding of the PHOSITA would be assisted by examining

298. *Id.* at 1370.

299. See Eysenck, *supra* note 282, at 154; CREATIVITY IN SCIENCE, *supra* note 250, ch. 5 (collecting research that demonstrates qualities of highly creative individuals).

aspects of the psychological research that focus on the conduct of highly productive individuals.³⁰⁰

C. Scientific Creativity as the Exercise of Logic

A popular conception of scientists and engineers is that they possess an ability to accomplish difficult tasks using logic. One theory of creativity, fundamentally at odds with the genius view, considers logic as the basis of all problem solving.³⁰¹ Sometimes called the “business-as-usual perspective,” logic views insight as “either relatively unimportant or even nonexistent as a distinct cognitive phenomenon.”³⁰²

One significant proponent of logic as the driver of scientific advancement is Herbert Simon, a Nobel laureate in economics. Beginning in the 1950s, Simon and others proposed that creative thinking is one type of the larger class of problem-solving behavior.³⁰³ This hypothesis questioned existing literature that explored solutions based on the “phenomenon of ‘illumination,’ the sudden flash of insight that reveals the solution of a problem long pursued.”³⁰⁴ Simon challenged the notion that scientific creations require a fundamentally different thought process than more commonplace forms of thinking.³⁰⁵

According to Simon, advancement is based solely on logic, defined as “a prescription of norms of valid behavior (e.g., judging soundly, reasoning correctly and rigorously).”³⁰⁶ Simon described the discovery of scientific laws as being accomplished by the use of deductive logic that allowed for

300. Eysenck, *supra* note 282, at 171.

301. See Margaret A. Boden, *Creativity and Artificial Intelligence*, 103 ARTIFICIAL INTELLIGENCE, 347 (1998) [hereinafter *Creativity and Artificial Intelligence*].

302. Colleen M. Seifert et al., *Demystification of Cognitive Insight: Opportunistic Assimilation and the Prepared-Mind Perspective*, in THE NATURE OF INSIGHT 65, 68 (Robert J. Sternberg & Janet E. Davidson eds., 1995) [hereinafter *Demystification*]. Seifert notes that the KSR decision is inconsistent with cognitive research on creativity. See also Colleen M. Seifert, *Now Why Didn't I Think of That? The Cognitive Processes that Create the Obvious*, 12 LEWIS & CLARK L. REV. 489 (2008).

303. See, e.g., A. Newell et al., *The Process of Creative Thinking* (Jan. 28, 1959) (paper presented at the Symposium on Creativity Thinking, University of Colorado on May 16, 1958) (on file with author).

304. *Id.* at 1-3.

305. David Klahr & Herbert A. Simon, *Studies in Scientific Discovery: Complementary Approaches and Convergent Findings*, 125 PSYCHOL. BULL. 524, 525 (1999) (“[I]t remains an open question whether or not the processes that support creative scientific discovery are widely different from more commonplace thinking. We hypothesize that they are not.”).

306. Herbert A. Simon, *Does Scientific Discovery Have a Logic?*, 40 PHIL. OF SCI. 471, 473 (1973).

description “in purely finitary terms.”³⁰⁷ Rather than relying on unconscious processing, Simon hypothesized that logic entails “a set of normative standards for judging the processes used to discover or test scientific theories, or the formal structure of the theories themselves,” which may be informed by empirical data.³⁰⁸ Simon maintained that this same process was equally applicable to minor advances and the generation of revolutionary scientific theories.³⁰⁹

Some theorists who work from the premise that logic forms the basis of scientific advances divide problem-solving methods into two types. The first, reliant on strong methods, uses the available information within the field that is directly relevant to the particular problem at hand.³¹⁰ Strong methods include expertise, experience in the relevant field, accumulated knowledge, established theories, specialized instrumentation and known procedures and paradigms, among other things.³¹¹

By contrast, weak methods are generally applicable methods of solving problems to be used when stronger methods cannot provide a ready solution.³¹² For example, one may be required to work backward from a goal – that is, one hypothesizes a solution and then considers whether evidence can be gathered for testing or confirmation.³¹³ Other strategies include hill-climbing, which refers to a decision-making process whereby one chooses the path that, among other available paths, brings one closest to a goal. A means-end analysis examines the differences between the present state of knowledge and a goal and then attempts to eliminate the most significant of those differences. Yet another is planning, where one uses the imagination to test out a solution mentally to determine whether an option is worth pursuing.

Building on Simon’s work, Dr. Robert Weisberg explains that, during problem finding and problem solving, both strong and weak methods may be used to reach a resolution.³¹⁴ Like Simon, Weisberg doubts that creative solutions derive from flashes of insight that emerge from the mind’s uncon-

307. *Id.* at 476.

308. *Id.* at 473.

309. *Id.* at 478 (“We know that all that is required to generate an infinite number of elements from a finite set of primitives is some kind of recursively applicable rule of generation. Thus, *modus ponens* applied to a small finite set of axioms may suffice to generate an infinity of theorems . . .”).

310. Klahr & Simon, *supra* note 305, at 532.

311. *Id.*; UNDERSTANDING INNOVATION, *supra* note 249, at 168-78.

312. *See* Newell et al., *supra* note 303, at 49.

313. *Id.*

314. UNDERSTANDING INNOVATION, *supra* note 249, at 180. Weisberg points out that “strong” and “weak” methods of problem solving may be points on a continuum rather than categorical in nature. *Id.* (“[I]t may be more useful, as well as simpler, to consider those different categories to be points on a continuum of generality-specificity of expertise, rather than separate modes of problem solving.” (citation omitted)).

scious work.³¹⁵ Instead, Weisberg asserts that, during the process of solving problems, “thoughts follow one from another, or are related to one another,” according to a structure that is dependent on the past.³¹⁶ Under this definition, the process of *ordinary thinking* is responsible for answers to all open questions.³¹⁷ According to Weisberg, accomplished individuals begin by acquiring expertise in a chosen field, a process of practice and the development of expertise.³¹⁸ This skill-building phase becomes an antecedent to the process of problem solving within that individual’s domain, as well as serving as the foundation for strong problem-solving skills.

Both Simon and Weisberg acknowledge that certain problems require different strategies to resolve.³¹⁹ Questions that have already been decided within a field may be solved by strong, well-established methods.³²⁰ More difficult questions must be resolved by resort to weak methods; as Simon describes, “[W]e may predict that persons tackling problems whose solutions will have marks of novelty and require creativity will use very general methods that do not rely on specific knowledge about the problem domain.”³²¹ So-called “problem spaces” for simpler questions are relatively small – that is, one seeking solutions can find answers with relative ease from a well-developed and narrowly defined set of rules.³²² For example, a person determining the shortest path to a store two blocks away is working in a small problem space that uses a relatively simple and finite set of rules.³²³ One can resolve this problem in a relatively short period of time by looking at a map that was made to scale and calculating the measurement of a relatively small number of routes.

315. *Id.* at 387 (“[E]vidence for unconscious processing in creative thinking is very weak.”).

316. *Id.* at 576.

317. *Id.* at 575-76.

318. *Id.* at 222. Weisberg regards the time typically required to gain such expertise as ten or more years. *Id.* at 173-74.

319. See Herbert A. Simon, *Discovery, Invention, and Development: Human Creative Thinking*, 80 PROC. NAT’L ACAD. SCI. U.S. AM. 4569, 4570 (1983) [hereinafter *Discovery, Invention, and Development*] (“Problems that call for creativity are precisely the problems from domains that have not already been well worked over and in which sophisticated, systematic algorithms for solutions do not exist.”); UNDERSTANDING INNOVATION, *supra* note 249, at 141-44.

320. See *Discovery, Invention, and Development*, *supra* note 319, at 4570 (“If we are given a linear algebraic equation in one variable to solve, we simply apply a well-worn and over-learned algorithm to solve it.”).

321. *Id.*

322. See UNDERSTANDING INNOVATION, *supra* note 249, at 141 (discussing “small problem space[s] wherein] one strategy to solve the problem is to search that space completely . . . until you find a path that leads to a solution,” which contrasts with large problem spaces “that are too large for a person to search exhaustively”).

323. See *id.*

Other problems are not subject to easy resolution. For example, solving world hunger cannot be approached in the same way as resolving the store route problem because the levels of complexity are entirely different.³²⁴ For large problem spaces, one may need to undertake a process of discovery, or *problem finding*, as a preparatory measure. After engaging in this exercise, one may select a smaller sub-problem, such as determining how to grow a particular crop in an identified geographic area, as one aspect of the world hunger dilemma. By doing so, one can use logical methods to narrow the problem space by engaging in the weak methods to move, and ultimately limit, the problem space toward a solution.³²⁵

To support his theory, Weisberg traces the development of various works and advances, including Edison's invention of the light bulb.³²⁶ Weisberg notes that Edison began this work after developing other types of inventions, including those that used electricity.³²⁷ According to Weisberg's account, Edison began experimenting with carbon as a filament.³²⁸ At this time, all other efforts to use carbon filaments had failed.³²⁹ Edison's initial attempts to use carbon were no more successful, in part because then-existing pumps failed to create an adequate vacuum and the carbon burned out too quickly.³³⁰ These failures led Edison to experiment with platinum instead.³³¹ Edison ultimately determined that platinum failed, in part because escaping hydrogen caused holes in the platinum within an imperfect vacuum.³³² By 1879, Edison and his staff began to develop more effective vacuum pumps to facilitate the use of platinum.³³³ Edison found, however, that platinum continued to crack even with improved pumps.³³⁴ By October 1879, Edison switched back to working with carbon filament in the more perfect vacuum created by the newly developed pumps.³³⁵ At that juncture, Edison and his

324. See UNDERSTANDING INNOVATION, *supra* note 249, at 144-52.

325. *Id.* at 147-52.

326. Edison ultimately obtained a patent on the light bulb. See U.S. Patent No. 223,898 (issued Jan. 27, 1880).

327. UNDERSTANDING INNOVATION, *supra* note 249, at 274 (“[A] broad range of Edison’s expertise played a role. Edison began by trying to build on the past, so his initial work depended on his domain-specific expertise.”).

328. *Id.* at 272 (“Edison started his electric-light work in 1877, with a bulb containing a carbon burner in a vacuum.”).

329. *Id.* at 271-72.

330. *Id.*

331. *Id.* at 272.

332. *Id.*

333. *Id.* at 273 (“Using this [improved] pump, Edison was able to reduce the pressure inside the bulb to one-hundred-thousandths of normal atmospheric pressure, which was the most nearly complete vacuum then in existence.” (citation omitted)).

334. *Id.* (noting that improved pumps “did not solve the basic problems with platinum”).

335. *Id.*

staff successfully burned a carbonized cotton thread in the nearly complete vacuum for over fourteen hours, allowing Edison to deem the experiment a success and thereafter file for his U.S. patent.³³⁶

According to Weisberg, Edison's work grew from the expertise that he had developed working with other technologies of the time.³³⁷ Additionally, Edison's

impasse with platinum . . . led him to carefully examine the failed burners. There was no direct precedent for this, but it was a response to an impasse that seems not untypical, based on people's general knowledge: If something is not working as you expect to, examine it carefully to try to determine why.³³⁸

Weisberg argues that Edison's development of the light bulb represents a logical progression, combining strong and weak methods that led to the invention. In particular, Edison was able to rely on strong methods gained from his expertise with electricity, including analogies and consideration of the relevant literature that described pump vacuums.³³⁹ Edison's development of the light bulb also incorporated weak problem-solving methods, including the examination of the failures of the platinum experiments to determine the cause and to use this information to move further toward a solution.³⁴⁰ After examining the processes of other ground-breaking inventions, Weisberg posits that radical scientific advances are the result of domain-specific expertise combined with logical, structured thinking and that "[i]n no case was it necessary to postulate any sort of nonordinary thought process in order to understand the creative advance."³⁴¹

Weisberg acknowledges that significant advances built on logic are not necessarily predictable, even to the scientist or engineer who is ultimately responsible for the advance.³⁴² As Weisberg explains, novel spheres present challenges to one's ability to predict outcomes, and restructuring one's thoughts may be necessary after reaching an impasse.³⁴³

For Weisberg, although expertise and motivation differ between one individual and another, no idea is truly outside the range of the ordinary thinker. Pushing boundaries involves a logical progression from a foundation of

336. *Id.*

337. *Id.* at 274.

338. *Id.*

339. *Id.*

340. *Id.*

341. *Id.* at 280.

342. Weisberg & Hass, *supra* note 266. UNDERSTANDING INNOVATION, *supra* note 249, at 329-30. This is illustrated by Edison's shift from testing carbonized materials to platinum and then back to successful tests of carbonized materials after learning from successive failures. *See id.* at 272-73.

343. UNDERSTANDING INNOVATION, *supra* note 249, at 328, 329 tbl.6.6.

already existing information toward a solution, integrating newly discovered information in a step-by-step process. Rather than breaking with the past, those who support the logic view advance the theory that people build on pre-existing work without any leaps of insight. As Weisberg explains, “[c]reative thinkers use the past, in various ways, as the basis for the creation of the new,”³⁴⁴ whether solving an algebraic problem based on a well-known formula or inventing a system of algebra for the very first time.³⁴⁵

Supporters of the logic view of creativity have relied, in part, on computer simulations of scientific discovery dating at least as far back as 1958. These early efforts included programs designed to play chess, discover proofs for theorems and design an electric motor and were said to “lie in areas not far from what is usually regarded as ‘creative.’”³⁴⁶ These programs, fed with information available to the original scientist, have successfully re-created Kepler’s third law, Ohm’s law and Galileo’s laws for the pendulum and constant acceleration.³⁴⁷ However, although computerized re-creations were successful, the role of human intervention has been acknowledged in these endeavors.³⁴⁸ Thus, it cannot be said that these re-creations are solely the result of computer logic. Further, the extent to which human thinking can be explained according to replication by computers is a matter of debate. As Professor Boden wrote, nearly all of “today’s ‘creative’ computers are concerned only with exploring predefined conceptual spaces” that “may allow for highly constrained tweaking, but no fundamental novelties or truly shocking surprises are possible.”³⁴⁹

344. Weisberg & Hass, *supra* note 266, at 359. See also Klahr & Simon, *supra* note 305, at 540 (noting that problem-solving processes do not vary across disciplines).

345. UNDERSTANDING INNOVATION, *supra* note 249, at 126-27.

346. Newell et al., *supra* note 303, at 5-8.

347. Margaret A. Boden, *Computer Models of Creativity*, in HANDBOOK OF CREATIVITY 351, 358 (Robert J. Sternberg ed., 1999). Gary F. Bradshaw, Patrick W. Langley & Herbert A. Simon, *Studying Scientific Discovery by Computer Simulation*, 222 SCI. 971 (1983); Pat Langley, *Rediscovering Physics with BACON.3*, in 1 PROCEEDINGS OF THE SIXTH INTERNATIONAL JOINT CONFERENCE ON ARTIFICIAL INTELLIGENCE 505, 505-07 (1979).

348. For example, Dr. Pat Langley, who was involved in a number of such projects, explained that “developers’ intervention plays an important role even in historical models of discovery.” Pat Langley, *The Computer-Aided Discovery of Scientific Knowledge*, in PROCEEDINGS OF THE FIRST INTERNATIONAL CONFERENCE ON DISCOVERY SCIENCE 25, 36 (Setsuo Arikawa & Hiroshi Motoda eds., 1998).

349. *Creativity and Artificial Intelligence*, *supra* note 301, at 353. Boden suggests that one deficiency with these systems is a computer’s inability to evaluate whether results are successful. *Id.* at 354. However, she suggests that computers may be capable of generating human-like thinking if programmed with appropriate social or scientific criteria or standards for assessing value. *Id.*; see also MARGARET A. BODEN, *THE CREATIVE MIND: MYTHS AND MECHANISMS*, ch. 11 (1990) [hereinafter *MYTHS AND MECHANISMS*].

In the broadest sense, the logic view of creativity is the antithesis of KSR's PHOSITA construct. If, given sufficient time and motivation, every person is capable of solving the most difficult creative challenges, then every invention is reproducible using ordinary creativity. As Weisberg explains, "[C]reativity is based on ordinary thinking, which means that the cognitive characteristics of individuals who produce world-class innovations are not basically different from the rest of us."³⁵⁰ The notion that an inventor can sometimes develop something beyond the reach of one of ordinary skill cannot be sustained by the theory that views all problems as solvable under the same logical rubric. Under the logic view, then, all persons exercise ordinary creativity solving all problems, including those capable of a patentable invention. If all creativity is a function of logic, every person of ordinary skill will reproduce any patentable invention given sufficient time, expertise and motivation.

Nonetheless, some loose analogies between the law and the logic view might be drawn. The Federal Circuit's former iteration of the PHOSITA focused solely on experience and education. This construct bears a strong relationship to strong methods of problem solving. A meaningful delineation between the readily achievable answers and the more difficult ones can be drawn by the use of strong versus weak methods. The use of weak methods indicates that some form of creativity is needed to solve more complex questions. Thus, a PHOSITA who must rely on working backwards from the goal, hill-climbing, means-end analysis or the use of imagination for planning may be said to be engaged in patentable efforts and not ordinary creativity.

D. Creativity as a Break from the Past

Creativity studies have led some psychologists to conclude that the exercise of this attribute resembles the use of one's imagination, not logic. As one psychologist described, creativity can be thought of as "an unpredictable, chaotic, even inefficient process driven by an indulgent wealth of diverse and unusual imagery, associative richness and originality."³⁵¹ Philosopher Karl Popper, in a work paradoxically titled *The Logic of Scientific Discovery*, stated, "[T]here is no such thing as a logical method of having new ideas, or a logical reconstruction of this process. . . . [E]very discovery contains 'an irrational element', or 'a creative intuition.'"³⁵² Albert Einstein's writings describe scientific advancement as a process evidenced by a nonverbal mode of thought where visual elements are evident:

350. UNDERSTANDING INNOVATION, *supra* note 249, at 598.

351. Dean Keith Simonton, *The Creative Process in Picasso's Geumica Sketches: Monotonic Improvements Versus Nonmonotonic Variants*, 19 CREATIVITY RES. J. 329, 330 (2007).

352. KARL POPPER, *THE LOGIC OF SCIENTIFIC DISCOVERY* 8 (2002).

The words or the language, as they are written or spoken, do not seem to play any role in my mechanism of thought. The psychological entities which serve as elements in thought are certain signs and more or less clear images which can be “voluntarily” reproduced and combined. . . . Conventional words or other signs have to be sought for laboriously only in a secondary stage³⁵³

In contrast to the logic perspective of creativity, the theories examined here hold that solving problems creatively invokes a thought process to generate new ideas that – although connected with existing information – represent a break with past thinking. As Henri Poincaré observed, “‘It is by logic we prove, it is by intuition we invent.’”³⁵⁴

Some courts appear to recognize that insight or intuition – rather than the application of step-by-step logic – weighs favorably in a finding of non-obviousness. This is evident in the former flash of genius standard, which relies on a sense of recognition, or insight, that might accompany a sudden mental resolution to a thorny problem. A modern example is *Ortho-McNeil Pharmaceutical, Inc. v. Mylan Laboratories, Inc.*, which was discussed earlier.³⁵⁵ The *Ortho-McNeil* court relied on findings that “the inventor’s insights, willingness to confront and overcome obstacles, and yes, even serendipity, cannot be discounted” in demonstrating nonobviousness.³⁵⁶ *Ortho-McNeil* suggests that patentability favors insight over logic.³⁵⁷ Similarly, the *KSR* opinion stated that inventions resulting from “fit[ting] the teachings of multiple patents together like pieces of a puzzle” are the mere exercise of simple logic that yield unpatentable results.³⁵⁸

1. Insight and Creativity

Einstein has been quoted as stating, “‘To these elementary laws there leads no logical path, but only intuition, supported by being sympathetically

353. Jacques Hadamard, *THE MATHEMATICIAN’S MIND: THE PSYCHOLOGY OF INVENTION IN THE MATHEMATICAL FIELD* app. II, at 142 (1973) (letter from Albert Einstein to Jacques Hadamard).

354. *ORIGINS OF THE SCIENTIFIC MIND*, *supra* note 9, at 90 (quoting Henri Poincaré).

355. 520 F.3d 1358 (Fed. Cir. 2008). *See supra* notes 217-19 and accompanying text.

356. *Id.* at 1364.

357. *Id.* *See also In re Huang*, 100 F.3d 135, 139 (Fed. Cir. 1996) (noting that references that suggest favorable properties of materials logically suggest to one of ordinary skill that limited experimentation will lead to success); *In re GPAC Inc.*, 57 F.3d 1573, 1578 (Fed. Cir. 1995) (A reference is pertinent if it “‘logically would have commended itself to an inventor’s attention in considering his problem.’” (quoting *In re Clay*, 966 F.2d 656, 659 (Fed. Cir. 1992))).

358. *KSR Int’l Co. v. Teleflex Inc.*, 550 U.S. 398, 420 (2007).

in touch with experience.”³⁵⁹ This articulation illustrates the theory that creativity derives from insight. The psychological study of insight as a human phenomenon has its origins in the early part of the last century, and the field has retained support in different forms today.³⁶⁰ The theory is not confined specifically to scientific creativity but to thinking and problem solving more generally.

As one source explains, “The term ‘insight’ designates the clear or deep perception of a situation, a feeling of understanding, the clear (and often sudden) understanding of a complex situation, or grasping the inner nature of things intuitively.”³⁶¹ The need for an insight may arise because one reaches an impasse – that is, the available knowledge and solutions fail to lead to an immediate solution, and a path toward an answer is not apparent.³⁶² In some cases, this is because the problem presented is complex or has aspects that have never been confronted before. In others, the impasse may be created by one’s erroneous preconception, assumption, block or lack of information in a usable form. In this instance, the problem solver enters a phase referred to as “incubation,” which

consists of putting the problem aside and thinking instead about other matters for an extended period of time. Then, at some point during incubation, there is an abrupt shift to the illumination phase, wherein a penetrating flash of insight about an appropriate satisfying resolution to the original problematic situation occurs unexpectedly. Given the attained insight, the final verification phase culminates with working out details of the resolution or determining that it applies successfully.³⁶³

When an insight problem is solved, the solver may experience the sense that the answer is both sudden and quite correct.³⁶⁴ A period of testing, refinement or verification may follow.

Insight involves mental restructuring. For example, one may need to restructure the problem at hand, as illustrated by a well-known example originating with Gestalt psychologist Max Wertheimer. This example is based on two boys – one of whom is older, more experienced and successful than the

359. SONJA C. GROVER, TOWARD A PSYCHOLOGY OF THE SCIENTIST: IMPLICATIONS OF PSYCHOLOGICAL RESEARCH FOR CONTEMPORARY PHILOSOPHY OF SCIENCE 68 (1981) (quoting Albert Einstein).

360. See *Grappling with Gestalt Psychology’s Unanswered Questions*, *supra* note 263, at 3 (describing the origins of the theory).

361. Edward M. Bowden & Mark Jung-Beeman, *Methods for Investigating the Neural Components of Insight*, 42 *METHODS* 87, 88 (2007).

362. See *Demystification*, *supra* note 302, at 86-87.

363. *Id.* at 75.

364. Bowden & Jung-Beeman, *supra* note 361, at 88-89.

other – playing badminton.³⁶⁵ The younger decides to discontinue play after losing several times. The older boy confronts a problem: he wishes to continue playing the game. Wertheimer pointed out that one solution to the problem involves engaging the younger boy by restructuring the goal of the game – competitive play – into one of cooperation. The older boy might, for example, engage the younger boy in counting out the number of times that both could keep the bird in play rather than attempting to create the incentive to continue playing an unwinnable game according to standard badminton rules.

A second example is restructuring a given set of information, such as the use of existing knowledge, in a different way. A widely cited example is an experiment that asks participants to tie two ends of strings together.³⁶⁶ In the room in which the experiment is conducted, strings hang from a ceiling, and various objects – including a chair, a jar and a pair of pliers, among other things – are scattered about.³⁶⁷ The strings are positioned to hang too far apart for a person to reach the ends of both.³⁶⁸ An individual can solve the problem by tying the pliers to the end of one string then using it as a pendulum to bring its end closer to the other, where the problem solver is located.³⁶⁹ By catching the pliers as they are swung, the person can then tie the strings' ends together.³⁷⁰ The problem requires a person to reformulate the typical use of pliers (as a tool) to another (as a pendulum) to provide the solution.³⁷¹

A more precise explanation of what occurs during insight has not been the subject of uniform agreement. Numerous efforts have been made to support the insight theory with empirical work, typically through the use of testing in controlled environments.³⁷² The research discloses that an incubation period is common; some view this time period as involving subconscious processing of information.³⁷³ As one researcher describes, “Our respondents unanimously agree that it is important to let problems simmer below the threshold of consciousness for a time.”³⁷⁴ One engineer stated,

365. See Roger L. Dominowski & Pamela Dallob, *Insight and Problem Solving*, in *THE NATURE OF INSIGHT* 34, 50-51 (Robert J. Sternberg & Janet E. Davidson eds., 1995) (recounting Wertheimer's story).

366. See *Demystification*, *supra* note 302, at 78-80 (describing experiment given to subjects by N.R. Maier).

367. *Id.*

368. *Id.*

369. *Id.*

370. *Id.*

371. *Id.*

372. See ROBERT J. STERNBERG & JANET E. DAVIDSON, *THE NATURE OF INSIGHT* (1995) (containing several examples).

373. *Demystification*, *supra* note 302, at 78-80; Jonathan W. Schooler & Sonya Dougal, *Why Creativity Is Not Like the Proverbial Typing Monkey*, 10 *PSYCHOL. INQUIRY* 351, 355 (1999).

374. MIHALY CSIKSZENTMIHALYI, *CREATIVITY: FLOW AND THE PSYCHOLOGY OF DISCOVERY AND INVENTION* 98 (1996).

I will tell you one thing that I found in both science and technology: If you have a problem, don't sit down and try to solve it. Because I will never solve it if I am just sitting down and thinking about it. It will hit me in the middle of the night, while I am driving my car or taking a shower, or something like that.³⁷⁵

Others report that there are visual components to such thoughts.³⁷⁶ Some theorists believe that the incubation period allows additional information – whether from the external world or from one's internal memory – to reach the problem solver and trigger resolution.³⁷⁷ A common example of this latter theory is the instance whereby mathematician Archimedes discovered a method for measuring the volume of an irregularly shaped object upon stepping into the bath and noticing the displacement of water.

The research results suggest that insight involves mental activity that is distinct from the process of merely remembering. This suggests that questions such as “what is the capital of the United States?” confront different problem-solving processes than “how can we solve environmental problems in the Washington, D.C. area?” Paradoxically, in one study, individuals with higher IQ's took a longer period of time to solve insight problems than those with lower IQ's.³⁷⁸ Generally, all test takers tended to have lower feelings of confidence for answers to insight questions that ultimately proved to be correct when compared to answers for non-insight questions.³⁷⁹

Very recent research into insight has examined whether a neurophysical basis exists to support the theory that insight plays a critical role in creativity.³⁸⁰ By tracing brain activity, such research attempts to establish solid evidence about brain function in the acts of exploring novel activity and forming new solutions.³⁸¹ Although controversial,³⁸² one recent paper asserts that insight derives from working memory that involves functions of the cerebellum:

375. *Id.* at 99 (quoting Frank Offner).

376. *Demystification*, *supra* note 302, at 78-80.

377. *Id.* at 82-83.

378. See Janet E. Davidson, *The Suddenness of Insight*, in *THE NATURE OF INSIGHT* 125, 126 (Robert J. Sternberg & Janet E. Davidson eds., 1995).

379. *Id.*

380. See Larry R. Vandervert et al., *How Working Memory and the Cerebellum Collaborate to Produce Creativity and Innovation*, 19 *CREATIVITY RES. J.* 1 (2007).

381. *Id.*

382. See Jason Brown, *On Vandervert et al. "Working Memory, Cerebellum, and Creativity"*, 19 *CREATIVITY RES. J.* 25, 25 (2007) (stating that there is an “absolute lack of evidence for the theory”); Masao Ito, *On "Working Memory and the Cerebellum Collaborate to Produce Creativity and Innovation" by L. R. Vandervert, P. H. Schimpf, and H. Liu*, 19 *CREATIVITY RES. J.* 35, 37 (2007) (recognizing that the proposed models “are still highly hypothetical in nature”).

Whenever a person confronts a novel problem, whether it be in the context of ancient-era survival situations, a series of novel problems facing Edison as he worked on the telephone or the electric light, or an expert working through the incremental, long-term steps of acquiring exceptional mastery, exploratory cerebellar modulations of cortical activity associated with working memory are the fundamental sources of creative and innovative solutions.³⁸³

Such research considers hypotheses about the mental act of creation, including that “sudden bursts of neural activity might certainly be expected to occur upon the formation of a new, multilayer concept which might take the form of, for example, insight related to a mathematical axiom.”³⁸⁴ Despite criticisms, researchers continue to attempt to understand brain activity during the creation of new ideas.³⁸⁵

2. Creativity and Chance: Invention as a Darwinian Process

As the earlier discussion of the Federal Circuit’s *Ortho-McNeil* decision suggests, serendipity may play a significant role in the creation of new ideas. The view that unguided generation and selection of ideas is fundamental to the creative process has been attributed to social scientist Donald T. Campbell, who disclaimed that significant advances were solely due to genius.³⁸⁶ Campbell theorized that deriving creative solutions included a process of generating multiple variations of possible answers followed by a scientist’s subsequent selection of the most promising options.³⁸⁷ This process, called “blind-variation-and-selective-retention,” was asserted to be Darwinian in nature – that is, disparate possibilities are generated in a manner analogous to Charles Darwin’s theory of biologic variation.³⁸⁸ Just as Darwin explained that some species survived while others failed, Campbell proposed that, after ideas are generated in an unguided fashion, a scientist’s evaluation of the multiplicity of possibilities would then lead to a useful, creative solution.³⁸⁹

Under Campbell’s theory, this generation of possibilities is “blind” in the sense that one cannot be certain of the merits of these preliminary thoughts at the time they are generated. By considering the inappropriate, the accidental and the impossible, Campbell posited that “breakouts from the

383. *Id.* at 10.

384. *Id.* at 15.

385. Bowden & Jung-Beeman, *supra* note 361, at 88-89. Masao Ito, *Control of Mental Activities by Internal Models in the Cerebellum*, 9 NATURE 304 (2008).

386. Donald T. Campbell, *Blind Variation and Selective Retention in Creative Thought as in Other Knowledge Processes*, 67 PSYCHOL. REV. 380, 391 (1960).

387. *Id.* at 384.

388. *Id.* at 384-85, 393.

389. *Id.* at 393.

limits of available wisdom” can be achieved.³⁹⁰ This process is illustrated in an essay by Poincaré that describes the process of formulating a mathematical theory: “One evening, contrary to my custom, I drank black coffee and could not sleep. Ideas rose in crowds; I felt them collide until pairs interlocked, so to speak, making a stable combination.”³⁹¹ Campbell acknowledged that some individuals are more successful at this process than others, perhaps due to differences in one’s ability to generate ideas or edit unsuccessful alternatives, among other things, all of which maximized the possibilities for higher rates of success.³⁹² However, Campbell believed that all individuals – even the extraordinarily talented – are subject to the “mental floundering and blind-alley entrances of the kind we are aware typify our own thought processes.”³⁹³

Building on Campbell’s work, psychologist Dean Keith Simonton asserts that chance plays a primary role in the creation of scientific works.³⁹⁴ Although acknowledging that ability, logic and other factors play their respective roles, Simonton argues “that creativity requires something that closely approximates a random combinatorial process.”³⁹⁵ Existing pieces of information and thoughts are combined according to chance, as described by Poincaré.³⁹⁶ Although one may have a good mechanical memory to create inventions, Simonton writes that engagement in a process to make associations between distinct ideas is vital to the creation of original combinations. According to this theory, a remarkably small number of these may be useful or interesting. These principles form the basis of Simonton’s view that chance plays a fundamental role in creative results. As he describes it,

Given that successful associations . . . are so rare, the odds of chancing upon the most fruitful association sequence . . . arrives early, sometimes a bit later and yet other times even later still. Essentially, the incubation period behaves like a game of craps in which a winning throw has the same chance of appearing no matter how long the gambler has been playing the game.³⁹⁷

Simonton explains that one who generates one or two ideas drawing from obvious source material will be unlikely to generate novel and useful results. By contrast, the ability to generate a high quantity of associations among a broad range of diverse ideas raises the possibility of a useful solu-

390. *Id.* at 380 (internal quotation marks omitted).

391. H. POINCARÉ, *THE FOUNDATIONS OF SCIENCE* 387 (George Bruce Halsted trans., 1913).

392. Campbell, *supra* note 386, at 391-92.

393. *Id.* at 391.

394. *See* CREATIVITY IN SCIENCE, *supra* note 250, at 162.

395. *Id.*

396. *See supra* note 391 and accompanying text.

397. *Id.* at 108.

tion. In the broadest sense, chance theory holds that the random generation of chance combinations, if successful, leads to previously unforeseeable possibilities.³⁹⁸ Under the chance view, one may not be consciously aware of the broad range of variations that are considered.³⁹⁹ Simonton states that the chaotic, subconscious combinatorial process “largely takes place below the threshold of awareness” and that “[o]nly when these operations obtain possible good combinations will one of their products pop into focal awareness.”⁴⁰⁰

These concepts and associations formed by individuals do not arise in a vacuum. Chance theory holds that the ability to create associations is based on pre-existing information that combines with the creator’s prior knowledge and experiences.⁴⁰¹ In many cases, creative results require input from both close and so-called “remote” sources – that is, antecedents that are “less obvious, relevant, predictable or commonplace.”⁴⁰²

One critical aspect of Simonton’s theory reinforces Campbell’s view that creative variations are blind.⁴⁰³ The use of the term “blind” infers a lack of direction that is not necessarily random. That is, the ideas generated are essentially unguided, which introduces an element of chance or randomness in creation.⁴⁰⁴ For example, “when a radar systematically sweeps the skies, it is acting according to the principle of blindness because it is not being guided by any a priori ideas about where an airplane or missile is most likely to be found.”⁴⁰⁵ Although variations may be constrained by immutable restrictions within the relevant domain, they remain – to some degree – unconstrained by a focus on obtaining a specific result.⁴⁰⁶ Prior to selection and retention, these variations may be “unrestrained, disorderly, and maybe even fantastic.”⁴⁰⁷

This perspective of creativity does not necessarily conflict with others but takes place within a larger framework of a creative process. Thus, at least one proponent of this view acknowledges that a creator assesses the most

398. *See id.* at 162-65.

399. *Id.* at 178-79.

400. *Id.*

401. *See* Dean Keith Simonton, *Picasso’s Guernica Creativity as a Darwinian Process: Definitions, Clarifications, Misconceptions, and Applications*, 19 CREATIVITY RES. J. 381, 384 (2007) [hereinafter *Guernica Creativity as a Darwinian Process*].

402. *See Darwin as Straw Man*, *supra* note 262, at 300.

403. *See* Dean Keith Simonton, *Creativity as Blind Variation and Selective Retention: Is the Creative Process Darwinian?*, 10 PSYCHOL. INQUIRY 309, 310 (1999).

404. *Id.* at 310-11.

405. *Id.*

406. *See id.* at 310-11 (defining the term “blindness” as “denot[ing] the lack of foresight in the production of variations – the inability to generate purposively the most adaptive variations”); *Darwin as Straw Man*, *supra* note 262, at 301.

407. *Guernica Creativity as a Darwinian Process*, *supra* note 401, at 384.

promising combinations using logic, expertise and experience.⁴⁰⁸ Further, logic can limit the types of combinations that are considered.⁴⁰⁹ Simonton acknowledges that the ability to draw from remote sources is based on the intellectual and personal attributes of the individual.⁴¹⁰ One assumption that Simonton incorporates is the view that creative scientists tend to have personality attributes that allow consideration of unlikely source material, such as openness to experiences that may trigger new associations and receptivity to novelty, complexity and ambiguity.⁴¹¹ Those able to generate the greatest volume of ideas, of the most richness and complexity, are more likely to have the most successful solutions.⁴¹² According to Simonton, “[A]t the highest levels of scientific creativity, chance and genius become synonymous.”⁴¹³

Moreover, the notion that creativity is based on chance does not suggest that motivation is absent or that incentives do not matter. Rather, one’s willingness to engage in extensive thought and trial and error can be critical to engaging in continued efforts that lead to a breakthrough.⁴¹⁴

3. Creativity as Cognition

Insight has been integrated into a cognitive model of problem solving that involves one or more cycles of the generation and exploration of ideas.⁴¹⁵ In the generation phase, one takes pre-existing information and from that makes analogues, synthesizes and transforms it and visualizes it into pre-inventive structures. In the exploratory phase, the problem solver works with the generated and restructured ideas to discover, interpret, test and examine the newly extended idea for new functions, perhaps for use in other contexts than the one from which the idea arose. This process takes place in light of broader constraints imposed by the nature of the project and the field within which it is intended to be used.

These theories define creativity as an attribute distinct from the pure exercise of logic. There are likely connections between them; in other words, the operation of creativity may use a combination of these techniques. For example, one psychologist proposes that chance may play a role in bringing

408. See CREATIVITY IN SCIENCE, *supra* note 250, at 162-65.

409. *Id.* at 165-66.

410. See *id.* at 171-77.

411. See *id.* at 172.

412. *Id.* at 176-77.

413. *Id.* at 179.

414. See *Darwin as Straw Man*, *supra* note 262, at 302 (discussing motivated persistence as a necessary part of most forms of creativity).

415. See RONALD A. FINKE ET AL., CREATIVE COGNITION: THEORY, RESEARCH AND APPLICATIONS (1992). An analysis of the KSR opinion, focusing particularly on the problem of hindsight bias, is explored in Steven M. Smith, *Invisible Assumptions and the Unintentional Use of Knowledge and Experiences in Creative Cognition*, 12 LEWIS & CLARK L. REV. 509 (2008).

information to a problem solver during incubation, causing the realization of a solution.⁴¹⁶ Other factors that may lead to a creative solution, such as following hunches and the ability to recognize patterns or organize knowledge, should not be left out of the calculus.⁴¹⁷

E. The Socio-Cultural Context: Invention as a Social Process

1. When Lightning Strikes Twice

A number of scientists working on the same problem may create the same invention independently and proximately in time. The phenomenon was recognized by the Supreme Court case *O'Reilly v. Morse*, which described the invention of the telegraph.⁴¹⁸ In that opinion, the Court noted that, as of 1832, the most significant obstacle to the implementation of a working telegraph was the lack of any method to keep galvanic current flowing with sufficient strength over long stretches of wire.⁴¹⁹ The *O'Reilly* opinion observed that the state of technological development encouraged a number of scientists to attempt to solve this problem:

[I]n this state of things it ought not to be a matter of surprise that four different magnetic telegraphs, purporting to have overcome the difficulty, should be invented and made public so nearly at the same time that each has claimed a priority; and that a close and careful scrutiny of the facts in each case is necessary to decide between them. The inventions were so nearly simultaneous, that neither inventor can be justly accused of having derived any aid from the discoveries of the other.⁴²⁰

Similarly, Frankfurter's dissent in *Marconi Wireless Telegraph Co. of America v. United States* noted that "the history of thought records striking coincidental discoveries – showing that the new insight first declared to the world by a particular individual was 'in the air' and ripe for discovery and disclosure."⁴²¹ This circumstance may exist due to an accumulation of knowledge that leads to an invention as a logical next step. This may be coupled with a domain's need to answer a pressing question or a societal desire for a

416. See Schooler & Dougal, *supra* note 373, at 352-53.

417. *Id.* at 355.

418. 56 U.S. 62, 107-08 (1853).

419. *Id.* at 107.

420. *Id.* at 107-08. See also Samson Vermont, *Independent Invention as a Defense to Patent Infringement*, 105 MICH. L. REV. 475, 478 (2006) ("This type of neck-and-neck finish is common. Researchers frequently converge on the same idea at roughly the same time." (citing examples)).

421. 320 U.S. 1, 62 (1943) (Frankfurter, J., dissenting).

solution, such as where a disease precipitates parallel research towards identifying a vaccine.

2. Simultaneous Inventions: Foundational Theories

Consistent with Frankfurter's observation that "[s]eldom indeed has a great discoverer or inventor wandered lonely as a cloud,"⁴²² sociologists and historians have observed a trend of multiple, nearly simultaneous independent invention. A number of them question whether coincidence alone can explain this phenomenon. Moreover, such researchers question the notion that invention occurs due to the "heroic and individualistic" efforts of singular inventors.⁴²³ Rather, some suggest that scientific advance is the product of sociological or cultural forces or perhaps an overall evolution of thought and practice embodied in those practicing within a field.⁴²⁴ As one source describes, "Research into multiple discoveries suggests that the process of scientific development . . . has a degree of independence from any particular inquiring mind."⁴²⁵

One early work by sociologists William F. Ogburn and Dorothy Thomas relies on a collection of 148 cited instances of multiple, independent discoveries.⁴²⁶ Ogburn and Thomas theorized that scientific advancement was the result of both the inventor's mental ability and some measure of "cultural preparation" in the form of a knowledge base that made significant advance possible.⁴²⁷ Ogburn and Thomas wrote that nearly simultaneous invention of the telegraph "leads one to think that electrical development was more dependent on cultural preparation than on genius."⁴²⁸ Likewise, they propose that Watt was not "indispensible to the perfection of the steam engine" and that "[i]t would be an absurdity to conclude that, even if he had died in infancy, the Industrial Revolution would not have occurred."⁴²⁹ This view of invention – sometimes called the zeitgeist view – places significant relevance on the accumulation of knowledge and the needs of society as key factors in scientific advance. As Francis Bacon observed, "[T]ime is the greatest innovator."⁴³⁰

422. *Id.*

423. D. LAMB & S.M. EASTON, *MULTIPLE DISCOVERY: THE PATTERN OF SCIENTIFIC PROGRESS* xv (1984).

424. *Id.* at 24-25 (describing the theory of evolutionary realism).

425. *Id.* at 24.

426. William F. Ogburn & Dorothy Thomas, *Are Inventions Inevitable? A Note on Social Evolution*, 37 *POL. SCI. Q.* 83, 93-98 (1922) (list of multiple, independent discoveries).

427. *Id.* at 92.

428. *Id.* at 88.

429. *Id.* at 91.

430. Francis Bacon, *Of Innovations*, in *ESSAYS OR COUNSELS CIVIL AND MORAL* (1625), reprinted in *THE HARVARD CLASSICS: ESSAYS, CIVIL AND MORAL AND THE*

Sociologist Roger Merton states the theory in its most extreme form, stating that “all scientific discoveries are in principle multiples, including those that on the surface appear to be singletons.”⁴³¹ According to Merton, inventions that appear to be singular and unique may be versions of unpublished, neglected or inaccessible multiples.⁴³² Alternatively, Merton proposes that those who might have become a second inventor may abandon the investigation, or the publication of the results, upon learning of an earlier scientist’s publication of a solution to the problem at hand.⁴³³ Relying on a group of 264 simultaneous, independent discoveries, Merton hypothesized that individualized scientific efforts were not critical to these advances and that “if any one of them had not arrived at the discovery, it would probably have been made in any case.”⁴³⁴

Merton acknowledges that significant breakthroughs will be made.⁴³⁵ Further, Merton does not view the occurrence of multiples as inconsistent with the fact that some inventors warrant the title of scientific genius.⁴³⁶ Instead, Merton attempts to harmonize these sociological and genius views of creativity by explaining that the advances made by the highly creative scientist would likely occur in any event.⁴³⁷ Specifically, he explains that the advances by such geniuses will take place “at a much slower pace, by a substantial number of other scientists, themselves of varying degrees of demonstrated talent.”⁴³⁸

Other scholars have considered the implications of simultaneous discovery. Some acknowledge that no discovery is truly inevitable where adequate financial support, robust research methods or other factors are lacking.⁴³⁹ Noted philosopher of science Thomas Kuhn identified a convergence of scientific, intellectual and social advances that temporally correlated to important scientific discoveries.⁴⁴⁰ Likewise, some scholars have concluded

NEW ATLANTIS BY FRANCIS BACON, AREOPAGITICA AND TRACTATE ON EDUCATION BY JOHN MILTON, RELIGIO MEDICI BY SIR THOMAS BROWNE 65, 65 (Charles W. Eliot ed., 1909).

431. Robert K. Merton, *Singletons & Multiples in Scientific Discovery: A Chapter in the Sociology of Science*, 105 PROC. AM. PHIL. SOC’Y 470, 477 (1961).

432. *Id.* at 478.

433. *Id.* at 479. Presumably, such publications include patents. Merton’s theory suggests that the patent system, which publishes applications and issued patents, could operate to terminate, rather than encourage, parallel inventive activity.

434. *Id.* at 483.

435. *Id.* at 474.

436. *Id.* at 483-84.

437. *Id.* at 484.

438. *Id.* at 485.

439. LAMB & EASTON, *supra* note 423, at 83-85.

440. Thomas S. Kuhn, *Energy Conservation as an Example of Simultaneous Discovery*, in THE ESSENTIAL TENSION: SELECTED STUDIES IN SCIENTIFIC TRADITION AND CHANGE (1977).

that these “breakthroughs are not necessarily the product of individual genius but are rather simmering in the scientific consciousness at any given time.”⁴⁴¹ Unlike Merton, who considers the role of individual scientists largely irrelevant, others have observed a symbiotic relation between discoveries and a broader scientific and societal framework.⁴⁴² This view holds that changes are the result of an evolution that derives from social, cultural and scientific pressures, built on an accumulation of information developed by others. An interdependent relation between the scientist and context leads to breakthroughs, including paradigm shifts of the largest order. As one source observes, “[I]t is not the genius who creates the paradigm but the paradigm that creates the genius who gives expression to it.”⁴⁴³

These theorists recognize that scientific breakthroughs require human endeavor but assert that this work must be contextualized within the rich variety of sources that support the evolution of any new idea. As Kuhn described the nearly simultaneous hypothesis of energy conservation from 1827 through 1847 by twelve different individuals, these discoveries grew from “the rapid and often disorderly emergence of the experimental and conceptual elements from which that theory was shortly to be compounded.”⁴⁴⁴ These theories, in sharp contrast to the genius view, hold that the birth of new information derives primarily from circumstances within the inventor’s intellectual and societal environment, rather than primarily through a singularly gifted individual.

3. Placing Multiples in Context

Some have observed that, “[u]ntil we can comprehend the skills and activities that make up the process of invention, we will find it difficult to determine the points at which larger external factors impinge on technological design.”⁴⁴⁵ The line between the scientist and the external context is not easy to draw. The staunchest proponent of this view, Merton, recognized that some advances waited for generations even though sufficient information to support the discovery existed.⁴⁴⁶ This suggests that the role of an individual scientist cannot be entirely discounted.

441. LAMB & EASTON, *supra* note 423, at 173. See also John C. Burnham, *Accident Proneness (Unfallneigung): A Classic Case of Simultaneous Discovery/Construction in Psychology*, 21 SCI. CONTEXT 99, 115 (2008); John Henry, *Ideology, Inevitability, and the Scientific Revolution*, 99 ISIS 552 (2008).

442. LAMB & EASTON, *supra* note 423, at 24-26.

443. *Id.* at 125.

444. Kuhn, *supra* note 440, at 72.

445. Michael E. Gorman & W. Bernard Carlson, *Interpreting Invention as a Cognitive Process: The Case of Alexander Graham Bell, Thomas Edison, and the Telephone*, 15 SCI. TECH. & HUM. VALUES 131, 133 (1990).

446. Merton, *supra* note 431, at 485.

Some question whether valid instances of multiples exist in fact.⁴⁴⁷ For example, isolating true multiples requires a critical step of defining the nature of the invention.⁴⁴⁸ To take a hypothetical example, one may conclude that multiple inventors created the light bulb. However, this characterization may mask technical distinctions between incandescent filament bulbs and fluorescents, which presented separate technical challenges at the time each was first made.

Some researchers have observed that similar inventions arise in distinct disciplines, casting doubt on the notion that these multiples are causally connected to a common mass of accumulated information. For example, B.S. Park considered multiple discovery relating to the concept of orbital hybridization.⁴⁴⁹ Generally, hybridization is an explanation of chemical bond formation that relates to mixing atomic orbitals, and therefore this discovery sits at “the borderland between physics and chemistry.”⁴⁵⁰ Both John C. Slater, who approached the problem as a physicist, and Linus Pauling, a chemist, are credited with this discovery.⁴⁵¹

Park’s work raises questions about the label “simultaneous discovery,” particularly where the goals of parallel research efforts are distinct.⁴⁵² For example, research intended to benefit one area of science may not have an immediately apparent applicable use in another. Indeed, Pauling actually attended a conference at which Slater presented some of his findings, and yet Pauling continued to devote considerable time and energy to work on the project.⁴⁵³ Park emphasizes that Slater’s contribution centered on hybridization relevant to physics and that, “[i]n short, although [Slater] dealt with valence and the electronic structure of molecules – fundamental questions in chemistry – his paper was not suitable for chemists to read.”⁴⁵⁴

Specifically, Park explains that Pauling delayed publication of his conclusions for three years because, in Pauling’s words, “I was having so much trouble getting a result that was in simple enough form to be valuable to

447. See, e.g., Augustine Brannigan & Richard A Wanner, *Historical Distributions of Multiple Discoveries and Theories of Scientific Change*, 13 SOC. STUD. SCI. 417, 420 (1983) (collecting research and concluding that “[a]lmost every close inspection of individual entries on lists of multiple discoveries has raised strong doubts regarding the equivalence of the contributors and/or the independence of the contributions”).

448. See Don Patinkin, *Multiple Discoveries and the Central Message*, 89 AM. J. SOC. 306, 308 (1983) (noting that the broader one characterizes the nature of a breakthrough, the more likely one is to find anticipation).

449. B.S. Park, *The Contexts of Simultaneous Discovery: Slater, Pauling, and the Origins of Hybridisation*, 31 STUD. HIST. PHIL. MOD. PHYSICS 451 (2000).

450. *Id.* at 452.

451. *Id.*

452. *Id.* at 451.

453. *Id.* at 468.

454. *Id.* at 462.

chemists”⁴⁵⁵ The intellectual diversity of these two scientists’ approaches discloses that the concept of simultaneous discovery does not mean that the later scientist’s work is a multiple in fact or scientifically irrelevant. As Park identifies, science may be riddled with disciplinary gulfs that limit the applicability of an advance at a moment in time. Park acknowledges that, although one field may provide information and input to others, a sociological view of simultaneous discovery does not fully account for the individual interests of distinct scientific fields.⁴⁵⁶

The image of the PHOSITA laboring alone in a workshop, manifest in the *Winslow* case,⁴⁵⁷ appears to ignore the interdisciplinary influence of other fields and the information flow from a host of societal sources that influence problem solvers in fact. The more recent *KSR* opinion opens the nonobviousness analysis to consider the influence of external factors on the inventive process. By orienting the PHOSITA within a larger framework that considers whether a “design need or market pressure” exists that pushes one toward a particular solution, *KSR* urges analysis of accumulated information both within and outside the relevant domain as well as broader technological trends that drive change.⁴⁵⁸ *KSR* directs that the existence of factors that arise from sources outside the inventor’s mind are more likely to render a patent obvious, built on the assumption that patents are not acting as an incentive where the invention would have likely arisen from societal pressures and an accumulation of information. As the *KSR* opinion explains, “Granting patent protection to advances that would occur in the ordinary course without real innovation retards progress and may, in the case of patents combining previously known elements, deprive prior inventions of their value or utility.”⁴⁵⁹

4. Scientific Advancement and Social Interaction

A review of all nonobviousness decisions over time, including *KSR*, is remarkable for the absence of any observations about the creative influence of co-inventors. The *Winslow* court evokes an image of the hypothetical per-

455. *Id.* at 466 (quoting Interview by John. L. Heilbron, Archive for the History of Quantum Physics, Am. Philosophical Soc’y Library, Philadelphia, with Linus Pauling).

456. Park, *supra* note 449, at 472.

457. See *supra* notes 105-10 and accompanying text.

458. *KSR Int’l Co. v. Teleflex Inc.*, 550 U.S. 398, 402, 417 (2007) (“[I]f a technique has been used to improve one device, and a person of ordinary skill in the art would recognize that it would improve similar devices in the same way, using the technique is obvious unless its actual application is beyond his or her skill.”). See also *id.* at 424 (“Technological developments made it clear that engines using computer-controlled throttles would become standard. As a result, designers might have decided to design new pedals from scratch; but they also would have had reason to make pre-existing pedals work with the engines.”).

459. *Id.* at 419.

son of ordinary skill in a solitary setting, and no U.S. case appears to have considered that inventive conduct by pairs, or groups, of inventors may operate differently. Further, the influence of non-inventors – including critics – is either not considered or weighs in favor of finding a claim nonobvious.⁴⁶⁰ Yet some research indicates that peers, including contrarians, may push inventors toward a breakthrough.

More specifically, some scholars have examined science as a social process, providing valuable input through the intellectual connection with, and input from, others.⁴⁶¹ Psychologist Kevin Dunbar explored this concept from a cognitive standpoint to attempt to understand how scientists gain insight in a laboratory environment.⁴⁶² Dunbar collected data over a one-year period examining all aspects of scientists' work in four different biology laboratories and found a number of similarities among them. Among these was a finding concerning scientists' reactions to inconsistent test results. Specifically, Dunbar found that scientists were rarely able to grapple internally with such evidence by making a significant mental shift.⁴⁶³ Rather, in the typical case the scientist could formulate a new hypothesis or conceptualize new information after an interaction with other scientists, which often "resulted in the phenomenological experience of insight in which the scientist exclaimed that [he or she] kn[ew] what was going on in the[] experiment."⁴⁶⁴

Additionally, Dunbar found that the social structure and intellectual diversity of the labs significantly affected whether scientists were able to solve more difficult problems.⁴⁶⁵ For example, Dunbar's research disclosed that "[w]hen all the members of the laboratory have the same knowledge at their disposal, . . . [and] when a problem arises, a group of like-minded individuals will not provide more information to make analogies than would a single individual."⁴⁶⁶

By focusing solely on the hypothetical reconstruction by a solo inventor, the law has lost valuable informational input about influences that actually push inventors toward, or away from, patentable solutions. The *KSR* Court instructed that a fact-finder assessing nonobviousness must consider contextual aspects of the invention, such as "the effects of demands known to the design community or present in the marketplace," and broaden considerations of prior art to that which serves "any need or problem known in the field of endeavor at the time of invention and addressed by the patent."⁴⁶⁷ Thus, *KSR*

460. See, e.g., *McGinley v. Franklin Sports, Inc.*, 262 F.3d 1339, 1351, 1353-54 (Fed. Cir. 2001) (Where the art "teaches away" from an invention, the invention is more likely to be found nonobvious.).

461. See Fuchs, *supra* note 287, at 933.

462. Dunbar, *supra* note 261, at 365.

463. *Id.*

464. *Id.* at 380.

465. *Id.* at 384-85.

466. *Id.* at 385.

467. *KSR Int'l Co. v. Teleflex Inc.*, 550 U.S. at 418-20.

requires a person of ordinary skill to consider references in other fields, stating that, where “a work is available in one field of endeavor, design incentives and other market forces can prompt variations of it, either in the same field or a different one.”⁴⁶⁸ In short, *KSR* pushes the ordinary scientist out from the isolation of the *Winslow* workshop and a step closer to a sociological context. To some degree, then, *KSR* opens the door to involve the cultural, social and scientific environment as part of the patentability decision. Yet it is not entirely clear whether *KSR* would allow information gleaned from co-inventors or contrarians who are not formally part of the prior art.

VI. MEANINGFUL IMPLEMENTATION OF *KSR*: ORDINARY CREATIVITY

A. *KSR and Ordinary Creativity*

This Section considers some of the implications of interdisciplinary research on the legal nonobviousness standard.⁴⁶⁹ *KSR*'s statement, “[a] person of ordinary skill is also a person of ordinary creativity, not an automaton,”⁴⁷⁰ represents a shift in the law. The phrase was one of several used by the Supreme Court to soften the Federal Circuit's previously rigid application of the “teaching, suggestion or motivation” test.⁴⁷¹

With respect to nonobviousness specifically, much of the *KSR* opinion evidences a deep connection with the cases of the *Graham* era.⁴⁷² Nonetheless, *KSR* displays a broadened perception about the nature of creative thought in a departure from nearly all prior law. Well before *KSR*, a number of courts discussed inventiveness as a product of the mind, a capability present in some individuals but not others or, alternatively, a quality that is not present in everyone all the time. For example, under *Hotchkiss*, a distinction existed between results obtainable from those who exercised mechanical skill and “the result of the exercise of the creative faculty.”⁴⁷³ These cases also relied on a separation between the application of a logical solution and the “product of intuition, or of something akin to genius.”⁴⁷⁴

468. *Id.* at 417.

469. Given that the scope of this work focuses on *KSR*, the impact of all of the implications of this interdisciplinary research on the patent system, and the intellectual property system more generally, have not been fully explored in this Article. The author is in the process of drafting subsequent materials that explore more of these implications.

470. *KSR Int'l Co.*, 550 U.S. at 421.

471. *Id.* at 418.

472. *See id.* at 415-18.

473. *Expanded Metal Co. v. Bradford*, 214 U.S. 366, 381 (1909).

474. *McClain v. Ormayer*, 141 U.S. 419, 426-27 (1891).

By contrast, *KSR* stirs capabilities into the person of ordinary skill, while considering knowledge present in the larger market relevant to the field of invention.⁴⁷⁵ The opinion opens an avenue for the person of ordinary skill to consider information available that is not spelled out in the prior art, such as “any need or problem in the field of endeavor,” including a design need or market pressure.⁴⁷⁶ Further, *KSR* directs that the person of ordinary skill be infused with some inferential capacity, such as the ability to work with known methods to obtain predictable results.⁴⁷⁷ The PHOSITA accomplishes that which is “obvious to try” without reaching a patentable level of inventiveness.⁴⁷⁸

Although *KSR* moves nonobviousness closer to modern conceptions of creativity formulated outside the law, the Court did not fully articulate the legal framework in which ordinary creativity should be understood. Moreover, the current state of patent law does not provide more than a few hints about the law’s understanding of creative processes. Efforts in other fields suggest that a comprehensive theoretical study of this subject can be undertaken and in some fields already has been studied.

B. Practical Implications of Creativity Research on the Nonobviousness Standard

Like many Supreme Court opinions, *KSR* is drafted in a manner that allows for flexible application to the myriad of nonobviousness challenges that are a vital part of the patent system. What are the *possible* ways that creativity can be defined for this purpose?

By statute, the PHOSITA’s effort to reconstruct the invention represents the starting point to the nonobviousness inquiry. The objective scope of the claim represents the endpoint. The determinative inquiry requires a hypothetical reconstruction of the invention by the PHOSITA between those two points. Yet patent law has never addressed precisely *where* the starting point is. Case law does not present a unified view. For example, in assessing non-obviousness, *Roche Molecular Systems* excluded all inventive activity that was not expressly embodied in the claims.⁴⁷⁹ In contrast, *Ortho-McNeil* cre-

475. *KSR Int’l Co.*, 550 U.S. at 421 (“When there is a design need or market pressure to solve a problem and there are a finite number of identified, predictable solutions, a person of ordinary skill has good reason to pursue the known options within his or her technical grasp. If this leads to the anticipated success, it is likely the product not of innovation but of ordinary skill and common sense.”).

476. *Id.* at 420.

477. *Id.* at 414-16.

478. *Id.* at 421.

479. 563 F. Supp. 2d 1016, 1038 (N.D. Cal. 2008) (“Even assuming the Stanford scientists were defying prevailing wisdom by choosing to study HIV RNA in plasma as a potential surrogate marker, this choice is not explicitly embodied in the patents-in-suit, nor did it immediately result in the patents-in-suit.”); *see also supra* notes

ditioned the inventor for starting down a “wrong pathway” by departing from his initial goal to develop a diabetes treatment and later shifting his research strategy to reach the claimed solution used to treat epilepsy.⁴⁸⁰ Interestingly, the *Ortho-McNeil* court assumed that the PHOSITA would have done the same and still found the claim nonobvious.⁴⁸¹ Creativity research suggests that *Ortho-McNeil* is the better-reasoned decision because such research recognizes that the process of defining a particular problem is creative in its nature.⁴⁸² Nonetheless, the courts have not articulated any definitive views on this point.

On a related issue, creativity research highlights the importance of identifying the problem to be solved when framing the *Graham* inquiry. That is, less defined problems require more creativity to solve. Unlike an improvement to existing technological solutions, questions that lack precedential guidance require one to generate entirely new ideas or logical constructs to answer them. Decision makers should be cognizant that the breadth of the question addressed by the claim has a significant effect on the nonobviousness result. Well-defined problems may call for narrow, readily obtainable solutions; “[i]t is said that a question well posed is half answered.”⁴⁸³ A problem that is specifically articulated is more likely to be deemed obvious. Conversely, more vaguely articulated problems appear more difficult to solve. To avoid skewing outcomes, fact-finders should be careful not to introduce hindsight bias or other linguistic distortion when framing the problem to be solved. Thus, the problem to be solved should attempt to track, to the extent possible, the problem as it existed within the state of the art prior to the date of invention.

Further, interdisciplinary research consistently recognizes that creative solutions push the state of existing knowledge forward. Creative ideas lead to a circumstance where “the world has turned out differently not just from the way we thought it *would*, but even from the way we thought it *could*.”⁴⁸⁴ Certainly, this research is consistent with patent law’s existing principle that a solution that overcomes a reference that “teaches away” from the inventor’s solution is nonobvious. Nonetheless, creativity theories indicate that the concept of “teaching away” is underinclusive. For example, research from the

223-31 and the accompanying text for more information about the *Roche Molecular Systems* decision.

480. 520 F.3d 1358 (Fed. Cir. 2008); *see also supra* notes 217-19 and the accompanying text for more information about the *Ortho-McNeil* decision.

481. 520 F.3d at 1364 (“[T]he ordinary artisan in this field would have had to (at the time of invention without any clue of potential utility of topiramate) stop at that intermediate and test it for properties far afield from the purpose for the development in the first place (epilepsy rather than diabetes).”).

482. *See, e.g.*, notes 262-64 and 319-25 and accompanying text.

483. Campbell, *supra* note 386, at 385 (quoting PAUL SOURIAU, *THEORIE DE L’INVENTION* 17-18 (1881)).

484. MYTHS AND MECHANISMS, *supra* note 349, at 31.

psychology of science finds that a solution may be deemed creative even if there is no specific information that precludes pursuing a particular solution. Rather, a creative solution may be something that has not yet been imagined, and therefore the merits and feasibility of the idea have not been assessed either way.

From a creativity perspective, solutions that readily derive from the collective state of knowledge, whether embodied in a reference or not, should not support a finding of nonobviousness. Likewise, solutions should not be patentable if they are merely based on a PHOSITA's ability to infer information from such sources. Solutions driven solely by external constraints, such as gravity pushing mass downward, are readily duplicated by a PHOSITA and therefore do not warrant a patent.

Creativity research uniformly recognizes that one engaging in creative thought must undergo some type of mental shift. Although the examples discussed in this piece are not exhaustive, some models used by theorists include unconventional thought processes, insight, chance or the use of a "weak method" of problem solving. The existence of any of these in a hypothetical person of ordinary skill demonstrates that more than ordinary creativity is needed to solve a problem.⁴⁸⁵

An invention based on the work of a PHOSITA who must generate multiple potential paths in a manner that invokes divergent thinking supports a patent grant.⁴⁸⁶ To use the facts of *Adams* as an example, if a PHOSITA attempting to re-create the water-activated battery would have had to exercise insight, or generate a number of variations of ideas, the invention would be found nonobvious.⁴⁸⁷ Alternatively, one might say that a PHOSITA's engagement in weak problem-solving techniques, such as creating a hypothesis coupled with testing, to accomplish the invention similarly result in a finding of a valid claim. Likewise, circumstances that require one to create a system, re-formulate a problem or engage in a broad search invoke both risk and creative choice, and therefore these conditions weigh in favor of finding the invention nonobvious. Solutions that require a PHOSITA to draw on knowledge outside the specific discipline relating to the claim at issue demonstrate more than ordinary creativity and therefore weigh in favor of a finding of nonobviousness.⁴⁸⁸

A claim should not be rendered invalid because it derives from already existing building blocks of information; indeed, all breakthrough ideas do so

485. Section 103 renders the inventor's process for formulating the claim irrelevant, and indeed there is anecdotal evidence that suggests that the assistance of a patent attorney who drafts the claim may play a role. Because the objective reach of the claim is the focus of the nonobviousness determination, the inventor's subjective experience does not assist in resolving this inquiry.

486. See *supra* note 252 and accompanying text.

487. See *supra* notes 98-102 and accompanying text.

488. See *supra* notes 278 and 452-54 and accompanying text.

in part.⁴⁸⁹ Such a finding would be erroneously overbroad, given that major innovations throughout history constitute advances based on – to some extent – what has gone before. Rather, it is the *degree* of the advance over the prior art that is the essence of the nonobviousness inquiry. Further, the notion that an inventor relied on routine methods to uncover a previously unforeseeable path can support a finding of nonobviousness. Although the methods used are part of the prior art, the claim may represent a breakthrough that warrants a patent, particularly if that testing discloses an anomalous result.⁴⁹⁰ Routine methods might be used to discover that which was previously unimaginable. The *KSR* opinion nowhere suggests that a PHOSITA has the ability to wonder.

Additionally, creativity theories can inform decision makers about the type of evidence that should be used for the hypothetical reconstruction of the invention. Decision makers may allocate the burden to demonstrate whether more than ordinary creativity has been exercised to assist the court in obtaining a sufficient factual basis to render a decision. However, some caution is warranted. Significantly, it may not be possible to ask an inventor to articulate a step-by-step logical methodology leading toward the invention in all cases. A substantial amount of literature supports an interpretation of creativity under which idea generation may occur during non-verbal thought, perhaps because such thinking is either subconscious or visual in its nature.⁴⁹¹ To the contrary, where the space between the problem and the solution is short, linear and explainable, it may be more likely that the claim is obvious. Thus, in instances where a PHOSITA might be expected to confront a seemingly insurmountable stumbling block, a claim should be deemed patentable even where the evidence shows that an unexplainable “leap” (or even backtracking) was required to get there.

Since the time that *KSR* was decided, it no longer appears appropriate to measure the person of ordinary skill’s capability *solely* with reference to a PHOSITA’s education level within the relevant art.⁴⁹² The Supreme Court created an additional attribute – ordinary creativity – to animate some capability of the person of ordinary skill. Further, *KSR* enforced its nonobviousness analysis with repeated references to its earlier jurisprudence, enforcing the notion of a flexible application.⁴⁹³ Yet such flexibility should not devolve into the uncertainty that doomed *Cuno*’s “flash of genius” standard, which introduced high levels of indeterminacy and subjectivity into the nonobviousness analysis.⁴⁹⁴ To the extent that *KSR* sought to mesh a legal understanding of creativity with the manner in which invention occurs in the real world,

489. See *supra* note 249 and accompanying text.

490. See *supra* note 265 and accompanying text.

491. See *supra* Part V.D.

492. See *supra* notes 118-20 and accompanying text.

493. *KSR Int’l Co.*, 550 U.S. 398, 416-18 (2007).

494. See *supra* notes 85-90 and accompanying text.

some guidance can be gleaned from the study of scientific creativity that considers qualities beyond education as indicative of the exercise of creative ability.

Questions relating to the PHOSITA's incentives present perhaps some of the most complex issues. The KSR Court observed that market incentives should be considered in assessing a PHOSITA's ability to re-create an invention.⁴⁹⁵ In *Roche Molecular Systems*, the court found a claim obvious because "[f]rom a cost/benefit perspective, there was a large incentive to pursue the option. . . ." presented in the claim at issue.⁴⁹⁶ Although both KSR and *Roche Molecular Systems* rely on incentives as a reason to deem a claim non-obvious in each case, from a creativity perspective there is a logical distinction between the two. Specifically, KSR's discussion of incentives relates to a suggestion to make a particular combination based on the proliferation of computerization techniques throughout the industry as a strong hint toward solving the gas pedal problem at hand. In contrast, the *Roche Molecular Systems* court referred to the financial or laudatory inducements that result from solving a problem, rather than the mental act that derives a solution. The KSR Court's concern about incentives centers on suggestions that drive a technical result; the *Roche Molecular Systems* court's concerns center on activities that are generally thought to be external to idea generation. Although nearly all of the creative theorists recognize that external support is *necessary* to support invention, such support is not always *sufficient* to support the human act of invention. Notably, a societal view of creativity is more sympathetic to the analysis in *Roche Molecular Systems* because such incentives indicate that conditions may be ripe for a zeitgeist in this particular field.⁴⁹⁷ Nonetheless, this same view recognizes the importance of adequate funding and other incentives as separately necessary to spur research from commencement to completion.⁴⁹⁸

Currently, discussions of inventive activity lack clear guidance. Inventions in the pharmaceutical industry highlight this problem. At present, there are areas of unpredictability within the field, although a significant number of the testing methods are well known. The judiciary's treatment of predictability does not provide sufficient direction for assessing nonobviousness.⁴⁹⁹ Specifically, it is not clear whether the nonobviousness focus should consider predictability *within an art* or instead to assess the predictability of discover-

495. 550 U.S. 398, 417 (2007) ("When a work is available in one field of endeavor, design incentives and other market forces can prompt variations of it, either in the same field or a different one.").

496. 563 F. Supp. 2d 1016, 1042 (N.D.Cal. 2008). See also *supra* notes 224-32 and accompanying text for the background for this decision.

497. See *supra* notes 423-25 and accompanying text.

498. See *supra* note 439 and accompanying text.

499. See *supra* notes 199-233 and accompanying text.

ing *the particular solution claimed*.⁵⁰⁰ The *KSR* Court did not articulate precisely how the predictability standard should apply where an inventive process relies on a mix of the predictable and the unpredictable. Some creativity theorists acknowledge that creative acts can take place within established domains, using already established methods.⁵⁰¹ Significantly, such research focuses particularly on the thoughts and actions taken that arrive at a particular solution rather than the state of a domain as whole. This suggests that inventions deriving from the use of established methods can result in nonobvious claims, so long as creativity is used in arriving at the resultant solution.

Further, *KSR* requires consideration of the social and intellectual environment in which an invention is made. Inventions may derive from the accumulation of knowledge, coupled with needs within a field or circumstances driving the need for a solution. Analyses of these theories suggest that the relation between an inventor and the surrounding environment is complex. As a whole, this research can be used to evaluate claims that an invention would have inevitably been created, given the sufficient passage of time and the absence of other considerations such as significant investment or experimentation. Moreover, the law of nonobviousness might consider how social interaction – such as that which occurs between co-inventors or collaborators for large-scale inventions – interacts with patent law’s incentive structure. The PHOSITA operating within the *Winslow* tableau is a useful image but ultimately one that lacks content. A stronger connection between the legal standard and the manner in which scientific creation actually occurs can be made, including for research that is performed collaboratively. Absent that foundation, nonobviousness might be assessed by examining some other construct that compares a claim with the state of the art that leaves the person of ordinary skill aside entirely.

In sum, the question of whether more than ordinary creativity is necessary for the PHOSITA to re-create an invention is a function of many different variables. For instance, whether the problem to be solved required thinking beyond that available through existing formulas, knowledge or limitations; whether a mental shift is required to reach the solution claimed; and whether the scientific, societal and external impact drove the PHOSITA toward the solution are all factors to be considered.

500. This point is evident through a comparison of *Pfizer Inc. v. Apotex*, 480 F.3d 1348 (Fed. Cir. 2007), and *Pfizer, Inc. v. Apotex, Inc.*, 488 F.3d 1377, 1378-79 (Fed. Cir. 2007) (order denying en banc rehearing) (Newman, Lourie & Rader, J.J., dissenting), as well as the majority and dissenting opinions in *Pharmastem Therapeutics, Inc. v. Viacell, Inc.*, 491 F.3d 1342 (Fed. Cir. 2007).

501. See *supra* note 264 and accompanying text.

C. Larger Implications for the Patent System

The person of ordinary skill was developed at a time when inventorship was primarily a solo activity and has weathered countless theoretical examinations of patent law throughout the years. That the model has persisted throughout this time may be a testament to its resilience. This legal fiction allows flexibility in the law's application to previously inconceivable advances across a broad array of subject matters. However, difficulties in implementing the PHOSITA standard suggest that patent law is perpetrating a construct that, although extraordinarily malleable, may fail to shed sufficient light on the considerations needed to optimally serve the patent system today. In some ways, *KSR* does not push far beyond the Court's 1850 *Hotchkiss* decision.

Decisions about the sufficiency of a creative breakthrough should not rest on mere assumptions, especially those founded in the 1850s. Otherwise, the enactment of section 103 did not resolve the vagueness of *Cuno's* ill-fated "flash of creative genius" standard.⁵⁰² Currently, the PHOSITA standard fails to provide certainty, flexibility or objective guidance. Rather, it is unclear whether a fact-finder will deem any particular invention obvious because it cannot be ascertained which assumptions about genius, predictability or the state of the art the fact-finder might hold. Such a construct cannot credibly support the most important patentability standard, and the rather difficult undertaking of some alternative will have to be devised. If such solutions cannot be developed, then this may demonstrate that the PHOSITA has outlived its usefulness.

Nonobviousness is at a crossroads. The patent system places a premium on objectivity, uniformity and certainty.⁵⁰³ Nonobviousness must be put into practice by thousands of patent examiners and used by innumerable rights holders, licensees, innovators and subsequent inventors who may wish to obtain a relatively solid assessment of a patent's validity. Minimizing reliance on the TSM test as the sole measure of nonobviousness, *KSR* emphasized that the Supreme Court's precedent requires an "expansive and flexible approach."⁵⁰⁴ At present, the PTO and the Federal Circuit cases implementing *KSR* have emphasized predictability as the touchstone of nonobviousness, however, the manner in which predictability has been applied seems quite muddled.

502. *Cuno Engineering Corp. v. Automatic Devices Corp.*, 314 U.S. 84, 91 (1941).

503. Cf. Paul M. Janicke, *On the Causes of Unpredictability of Federal Circuit Decisions in Patent Cases*, 3 NW. J. TECH. & INTELL. PROP. 93 (2005) (describing some of the values of predictability and harmony for judicial decision making in patent cases). See also Timothy R. Holbrook, *The Supreme Court's Complicity in Federal Circuit Formalism*, 20 SANTA CLARA COMPUTER & HIGH TECH. L.J. 1 (2003).

504. *KSR Int'l Co.*, 550 U.S. at 415.

If the person of ordinary skill in the art is retained, the phrase “ordinary creativity” is likely to have repercussions on other doctrines that are reliant on the PHOSITA standard.⁵⁰⁵ Beyond this, creativity research can assist in answering fundamental questions about the administration of the patent system more generally. The incentive structure of patent law might be allowed to shift in ways that are beneficial to the creative process. For example, the law analyzing diligence under the first to invent doctrine might be more tolerant of a scientist’s interest in pursuing multiple projects at the same time. Acknowledging a social aspect to creativity would allow us to consider whether the modern definition of “inventorship” adequately captures reality. The adequate disclosure doctrines might be enforced in a manner that recognizes that scientists who have access to information outside of their own narrow disciplines are better able to increase their abilities to invent within their own fields and thereby raise the total level of invention as a whole. Further, if one accepts an inevitable aspect to invention, one may be inclined to implement a system of narrower patent rights that more firmly supports competition between inventing entities and broadly available funding, rather than broader rights for the solo genius. Such a system would endeavor to maximize the opportunities, and thereby shorten the time frame, to generate breakthroughs.

VII. CONCLUSION

KSR has challenged patent lawyers, decision makers and theorists to consider the nature of invention in a broader, more flexible fashion. Ultimately, patent law is intended to promote the creativity of scientists and engineers. There are nuances in the conclusion that a step forward represents an adequate advance in an art that has remained unexplored to this point. By asking fundamental questions about how and why people create, interdisciplinary research can assist patent law in answering these questions. More broadly, such research can assist patent law’s understanding of the work that the system is designed to protect. Whether particular doctrines, or indeed the system as a whole, foster breakthroughs cannot be answered without an understanding of the manner in which such breakthroughs occur.

505. See *supra* note 22 for a list of these doctrines.

